

### General Description

These N-Channel enhancement mode power field effect transistors are using trench DMOS technology. This advanced technology has been especially tailored to minimize on-state resistance, provide superior switching performance, and withstand high energy pulse in the avalanche and commutation mode. These devices are well suited for high efficiency fast switching applications.

BVDSS	RDSON	ID
80V	100mΩ	12A

### Features

- 80V, 12A,  $R_{DS(ON)}=100m\Omega@V_{GS} = 10V$
- Improved dv/dt capability
- Fast switching
- 100% EAS Guaranteed
- Green Device Available

### TO251 Pin Configuration

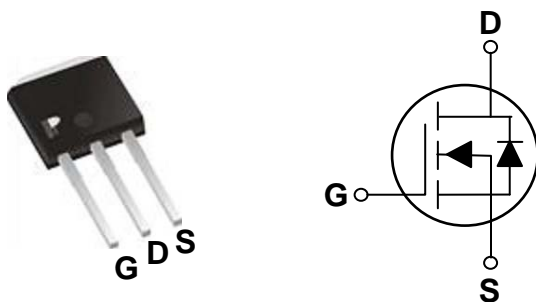

### Applications

- Motor Drive
- Power Tools
- LED Lighting



### Absolute Maximum Ratings $T_c=25^\circ\text{C}$ unless otherwise noted

Symbol	Parameter	Rating	Units
$V_{DS}$	Drain-Source Voltage	80	V
$V_{GS}$	Gate-Source Voltage	$\pm 20$	V
$I_D$	Drain Current – Continuous ( $T_c=25^\circ\text{C}$ )	12	A
	Drain Current – Continuous ( $T_c=100^\circ\text{C}$ )	7.6	A
$I_{DM}$	Drain Current – Pulsed <sup>1</sup>	48	A
$P_D$	Power Dissipation ( $T_c=25^\circ\text{C}$ )	35	W
	Power Dissipation – Derate above $25^\circ\text{C}$	0.28	W/ $^\circ\text{C}$
$T_{STG}$	Storage Temperature Range	-50 to 150	$^\circ\text{C}$
$T_J$	Operating Junction Temperature Range	-50 to 150	$^\circ\text{C}$

### Thermal Characteristics

Symbol	Parameter	Typ.	Max.	Unit
$R_{\theta JA}$	Thermal Resistance Junction to ambient	---	62	$^\circ\text{C}/\text{W}$
$R_{\theta JC}$	Thermal Resistance Junction to Case	---	3.6	$^\circ\text{C}/\text{W}$

**Electrical Characteristics ( $T_J=25^\circ\text{C}$ , unless otherwise noted)**
**Off Characteristics**

Symbol	Parameter	Conditions	Min.	Typ.	Max.	Unit
$BV_{DSS}$	Drain-Source Breakdown Voltage	$V_{GS}=0V, I_D=250\mu A$	80	---	---	V
$\Delta BV_{DSS}/\Delta T_J$	$BV_{DSS}$ Temperature Coefficient	Reference to $25^\circ\text{C}$ , $I_D=1\text{mA}$	---	0.09	---	$V/^\circ\text{C}$
$I_{DSS}$	Drain-Source Leakage Current	$V_{DS}=80V, V_{GS}=0V, T_J=25^\circ\text{C}$	---	---	1	$\mu A$
		$V_{DS}=64V, V_{GS}=0V, T_J=125^\circ\text{C}$	---	---	10	$\mu A$
$I_{GSS}$	Gate-Source Leakage Current	$V_{GS}=\pm 20V, V_{DS}=0V$	---	---	$\pm 100$	nA

**On Characteristics**

$R_{DS(ON)}$	Static Drain-Source On-Resistance	$V_{GS}=10V, I_D=10A$	---	77	100	$m\Omega$
		$V_{GS}=4.5V, I_D=8A$	---	80	115	$m\Omega$
$V_{GS(th)}$	Gate Threshold Voltage	$V_{GS}=V_{DS}, I_D=250\mu A$	1.2	1.8	2.5	V
$\Delta V_{GS(th)}$	$V_{GS(th)}$ Temperature Coefficient		---	-4.4	---	$mV/^\circ\text{C}$
$g_{fs}$	Forward Transconductance	$V_{DS}=10V, I_D=10A$	---	7	---	S

**Dynamic and switching Characteristics**

$Q_g$	Total Gate Charge <sup>2,3</sup>	$V_{DS}=40V, V_{GS}=10V, I_D=10A$	---	19.2	29	nC
$Q_{gs}$	Gate-Source Charge <sup>2,3</sup>		---	3.3	6	
$Q_{gd}$	Gate-Drain Charge <sup>2,3</sup>		---	3.5	7	
$T_{d(on)}$	Turn-On Delay Time <sup>2,3</sup>	$V_{DD}=30V, V_{GS}=10V, R_G=6\Omega$ $I_D=-1A$	---	5	10	ns
$T_r$	Rise Time <sup>2,3</sup>		---	25	50	
$T_{d(off)}$	Turn-Off Delay Time <sup>2,3</sup>		---	22	44	
$T_f$	Fall Time <sup>2,3</sup>		---	8	16	
$C_{iss}$	Input Capacitance	$V_{DS}=30V, V_{GS}=0V, F=1\text{MHz}$	---	1070	1550	pF
$C_{oss}$	Output Capacitance		---	40	60	
$C_{rss}$	Reverse Transfer Capacitance		---	35	50	
$R_g$	Gate resistance	$V_{GS}=0V, V_{DS}=0V, F=1\text{MHz}$	---	1	2	$\Omega$

**Drain-Source Diode Characteristics and Maximum Ratings**

Symbol	Parameter	Conditions	Min.	Typ.	Max.	Unit
$I_S$	Continuous Source Current	$V_G=V_D=0V$ , Force Current	---	---	12	A
$I_{SM}$	Pulsed Source Current		---	---	48	A
$V_{SD}$	Diode Forward Voltage	$V_{GS}=0V, I_S=1A, T_J=25^\circ\text{C}$	---	---	1	V

**Note :**

1. Repetitive Rating : Pulsed width limited by maximum junction temperature.
2. The data tested by pulsed , pulse width  $\leq 300\mu s$ , duty cycle  $\leq 2\%$ .
3. Essentially independent of operating temperature.

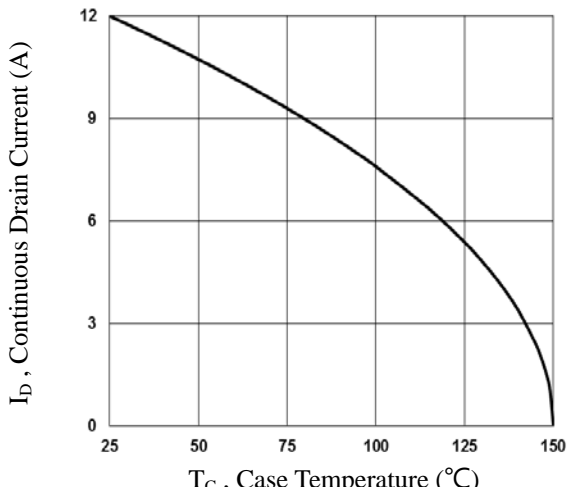

Fig.1 Continuous Drain Current vs.  $T_c$

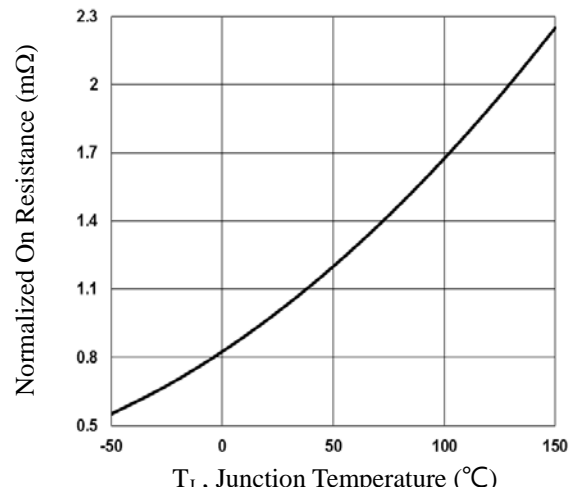

Fig.2 Normalized  $R_{DS(on)}$  vs.  $T_j$

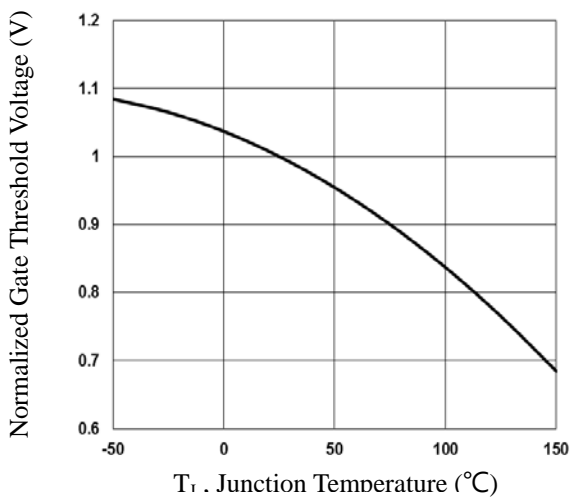

Fig.3 Normalized  $V_{th}$  vs.  $T_j$

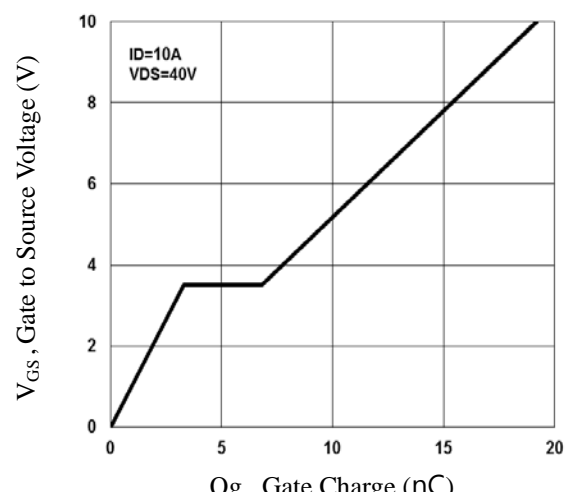

Fig.4 Gate Charge Waveform

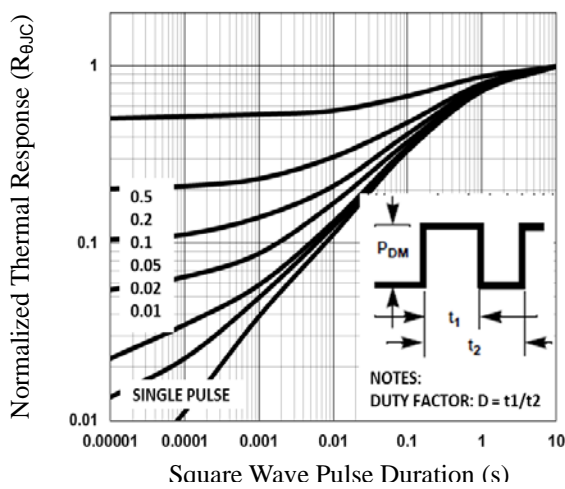

Fig.5 Normalized Transient Impedance

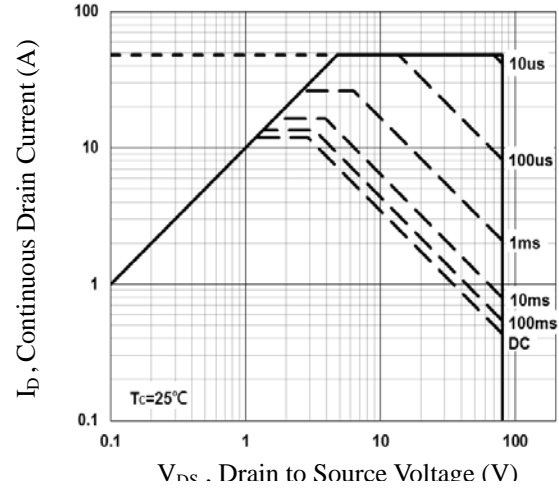

Fig.6 Maximum Safe Operation Area

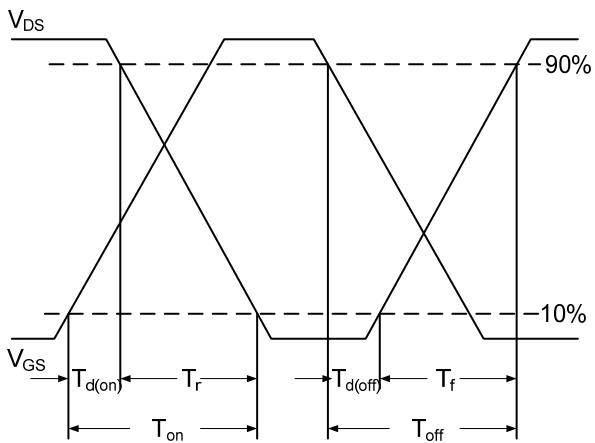

Fig.7 Switching Time Waveform

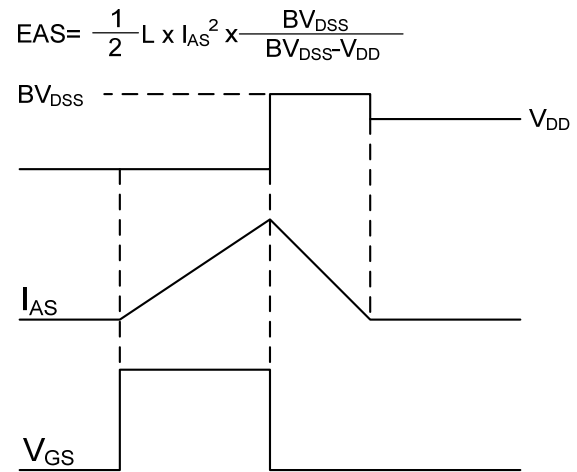
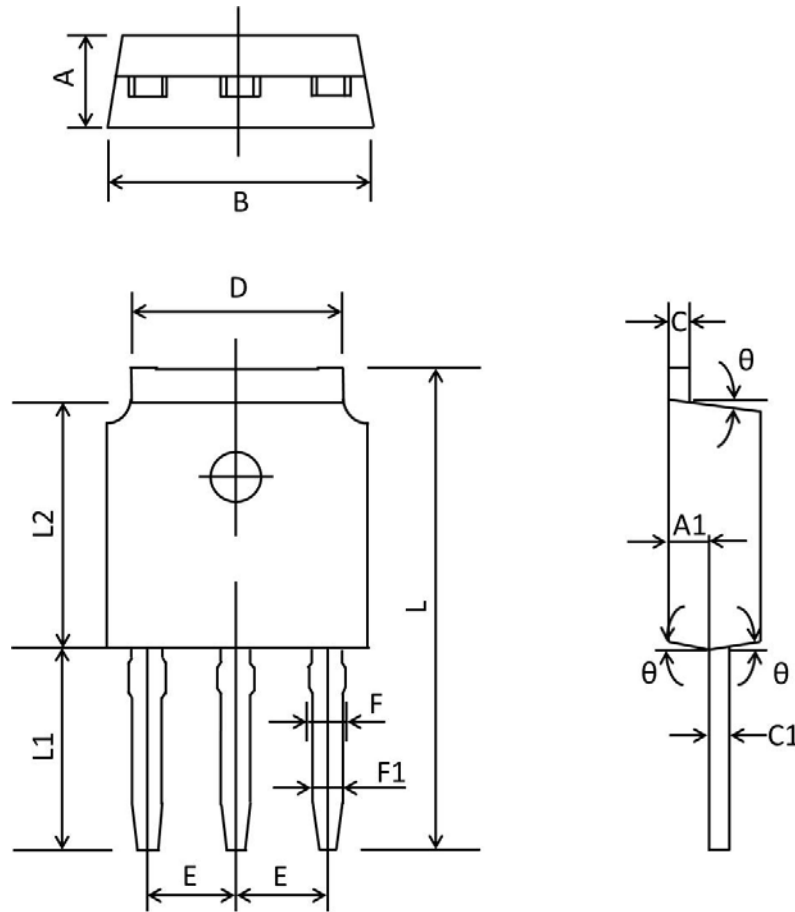

Fig.8 EAS Waveform



## TO251 PACKAGE INFORMATION



Symbol	Dimensions In Millimeters		Dimensions In Inches	
	Min	Max	Min	Max
A	2.20	2.40	0.087	0.094
A1	0.91	1.11	0.036	0.044
B	6.50	6.70	0.256	0.264
C	0.46	0.580	0.018	0.230
C1	0.46	0.580	0.018	0.030
D	5.10	5.46	0.201	0.215
E	2.186	2.386	0.086	0.094
F	0.74	0.94	0.029	0.037
F1	0.660	0.860	0.026	0.034
L	11.70	12.30	0.461	0.484
L1	4.8	5.2	0.189	0.205
L2	6.00	6.20	0.236	0.244
$\theta$	3°	9°	3°	9°