

SMBR30100CT-SMBRF30100CT

Trench Schottky Rectifier
Reverse Voltage 100 V Forward Current 30 A

Features

- Plastic package has underwriters Laboratory Flammability Classification 94V-0
- Dual rectifier construction, positive center tap
- Low forward voltage, high efficiency

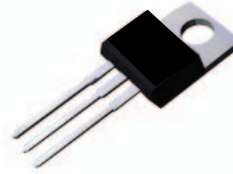

SMBR30100CT
Package: TO-220-AB

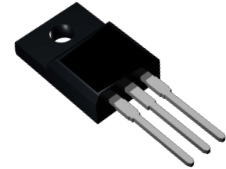

SMBRF30100CT
Package: ITO-220-AB

Mechanical Data

- Case: epoxy, molded
- Weight: 1.9grams (approximately)
- Finish: all external surfaces corrosion resistant and terminal leads readily solderable
- Lead temperature for soldering purpose: 260°C max. for 10 sec
- 50 units per plastic tube

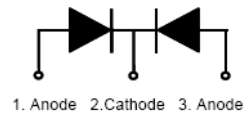

Schematic Diagram

Maximum Ratings & Electrical Characteristics

($T_A=25^\circ\text{C}$ unless otherwise noted)

Parameter	Test Conditions		Symbol	Value	Unit
Maximum Repetitive Peak Reverse Voltage			V_{RRM}	100	V
Working Peak Reverse Voltage			V_{RWM}	100	V
Maximum DC Blocking Voltage			V_{DC}	100	V
Maximum Average Forward Rectified Current @ $T_c=105^\circ\text{C}$	Total Device		$I_{F(AV)}$	30	A
	Per Diode			15	
Peak Forward Surge Current 8.3ms Single Half Sine-wave Superimposed on Rated Load per Diode			I_{FSM}	200	A
Peak repetitive Reverse Current Per Leg at $t_p=2.0\mu\text{s}$, 1KHz			I_{RRM}	1.0	A
Voltage Rate of Change (rated V_R)			DV/dt	10000	V/ μs
Operating Junction Temperature Range			T_J	- 55 to+150	$^\circ\text{C}$
Storage Temperature Range			T_{STG}	- 55 to+150	$^\circ\text{C}$
Isolation Voltage (ITO-220-AB only) from Terminal to Heatsink $t = 1 \text{ sec}$			V_{AC}	1500	V
Maximum Instantaneous Forward Voltage per Leg	$I_F=15\text{A}$ $I_F=15\text{A}$	$T_c=25^\circ\text{C}$ $T_c=125^\circ\text{C}$	V_F	0.72 0.62	V
Maximum Reverse Current per Leg at Working Peak Reverse Voltage		$T_J=25^\circ\text{C}$ $T_J=100^\circ\text{C}$		I_R	
Thermal Characteristics ($T_A=25^\circ\text{C}$ unless otherwise noted)					
Symbol	Parameter		Typ.(TO-220-AB)	Typ.(ITO-220-AB)	Unit
$R_{\theta JC}$	Thermal Resistance, Junction to Case per Leg		2.0	4.0	$^\circ\text{C}/\text{W}$
$R_{\theta JA}$	Thermal Resistance, Junction to Ambient per Leg		62.5	62.5	$^\circ\text{C}/\text{W}$

Note: Pulse test:300us pulse width, duty cycle=2%

SMBR30100CT-SMBRF30100CT

Trench Schottky Rectifier
Reverse Voltage 100 V Forward Current 30 A

Ratings and Characteristics Curves ($T_A = 25^\circ\text{C}$ unless otherwise noted)

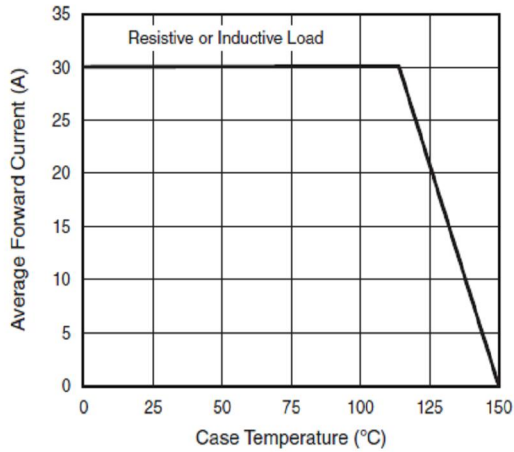

Fig. 1 - Forward Current Derating Curve

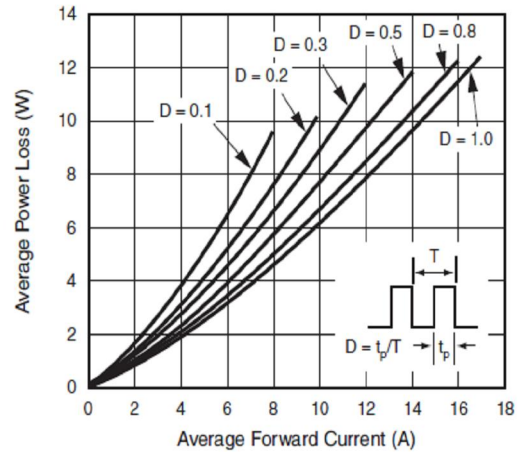

Fig. 2 - Forward Power Loss Characteristics Per Diode

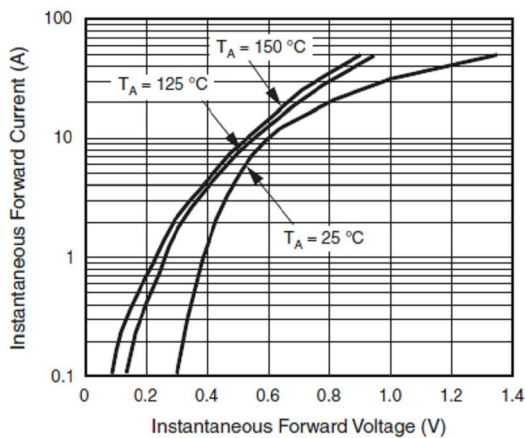

Fig. 3 - Typical Instantaneous Forward Characteristics Per Diode

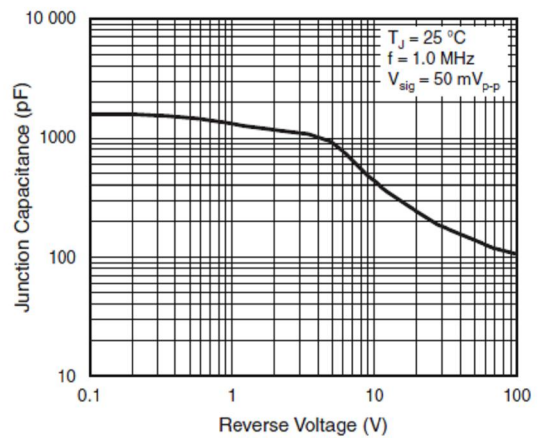

Fig. 5 - Typical Junction Capacitance

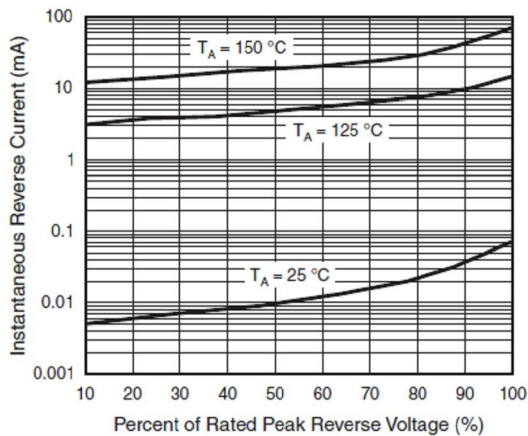

Fig. 4 - Typical Reverse Characteristics Per Diode

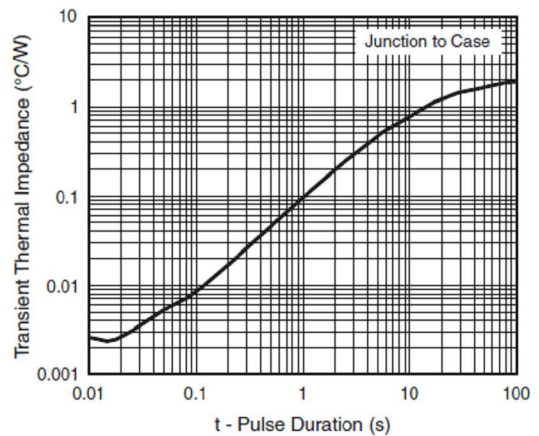

Fig. 6 - Typical Transient Thermal Impedance Per Diode

SMBR30100CT-SMBRF30100CT

Trench Schottky Rectifier
Reverse Voltage 100 V Forward Current 30 A

Package Outline Dimensions

in millimeters

TO-220-AB

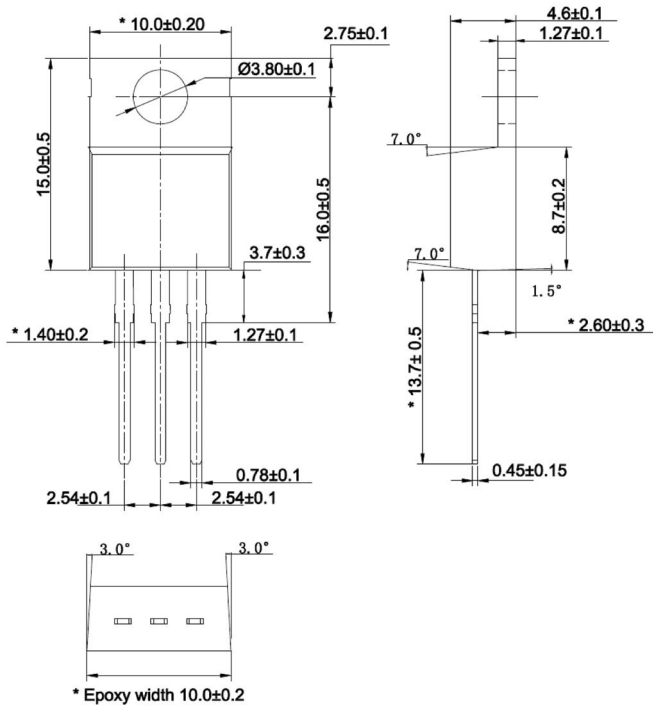

ITO-220-AB

