

MUR1060/MUR1060F

Ultrafast Recovery Rectifiers
Reverse Voltage 600V Forward Current 10 A

Features

- FRED (Planar) wafer construction
- Ultrafast recovery time
- Low forward voltage drop, low power loss
- High efficiency
- Plastic package has underwriters Laboratory Flammability Classification 94V-0

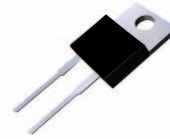

MUR1060
Package: TO-220-AC



MUR1060F
Package: ITO-220-AC

Mechanical Data

- Case: Epoxy, molded
- Weight: 1.9grams (approximately)
- Finish: all external surfaces corrosion resistant and terminal leads readily solderable
- Lead temperature for soldering purposes: 260°C Max. for 10 sec
- 50 units per plastic tube



Schematic Diagram

Maximum Ratings & Electrical Characteristics

($T_A=25^\circ\text{C}$ unless otherwise noted)

Parameter	Test Conditions		Symbol	Value	Unit
Maximum Repetitive Peak Reverse Voltage			V_{RRM}	600	V
Working Peak Reverse Voltage			V_{RWM}	600	V
Maximum DC Blocking Voltage			V_{DC}	600	V
Maximum Average Forward Rectified Current @ $T_c=105^\circ\text{C}$ Total Device per Diode			$I_{F(AV)}$	10	A
Peak Forward Surge Current 8.3ms Single Half Sine-wave Superimposed on Rated Load per Diode			I_{FSM}	125	A
Isolation Voltage from Terminal to Heatsink $t=1$ min	ITO-220-AC		V_{AC}	1500	V
Operating Junction Temperature Range			T_J	- 55 to+150	$^\circ\text{C}$
Storage Temperature Range			T_{STG}	- 55 to+150	$^\circ\text{C}$
Maximum Reverse Recover Time ($I_F=0.5\text{A}$, $I_R=1.0\text{A}$, $I_{rec}=0.25\text{A}$)			T_{rr}	50	ns
Maximum Instantaneous Forward Voltage per Leg	$I_F=10\text{A}$	$T_C=25^\circ\text{C}$	V_F	1.60	V
	$I_F=10\text{A}$	$T_C=125^\circ\text{C}$		1.50	
Maximum Reverse Current per Leg at Working Peak Reverse Voltage		$T_J=25^\circ\text{C}$	I_R	10	μA
		$T_J=100^\circ\text{C}$		500	μA
Thermal Characteristics $T_A=25^\circ\text{C}$ unless otherwise noted					
Symbol	Parameter		Typ.(MUR1060)	Typ.(MUR1060F)	Unit
$R_{\theta JC}$	Thermal Resistance, Junction to Case per Leg		2.0	4.0	$^\circ\text{C}/\text{W}$
$R_{\theta JA}$	Thermal Resistance, Junction to Ambient per Leg		62.5	62.5	$^\circ\text{C}/\text{W}$

Note: Pulse test:300us pulse width, duty cycle=2%

MUR1060/MUR1060F

Ultrafast Recovery Rectifiers
Reverse Voltage 600V Forward Current 10 A

Ratings and Characteristics Curves ($T_A = 25^\circ\text{C}$ unless otherwise noted)

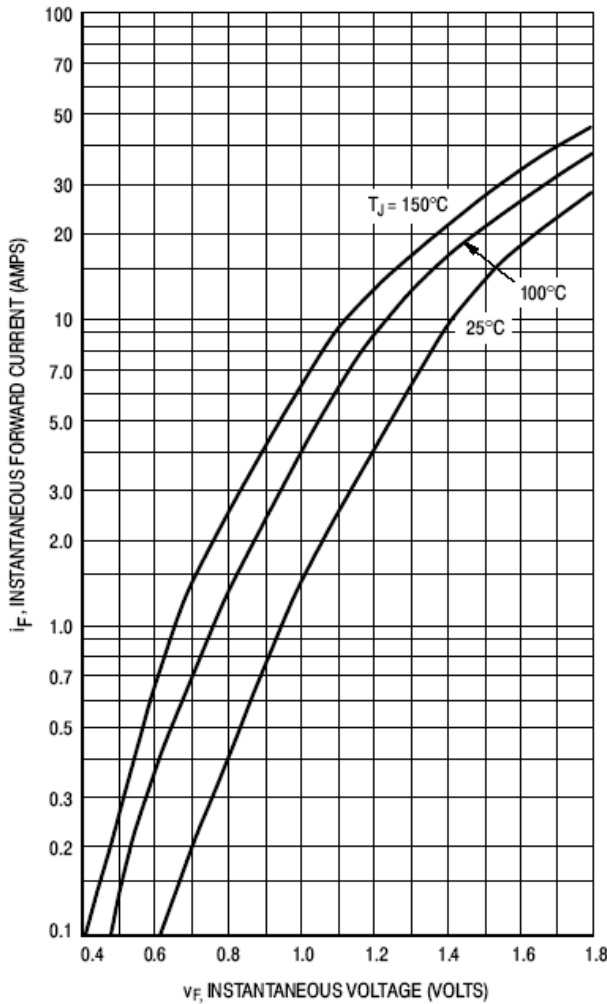

Figure 1. Typical Forward Voltage Per Leg

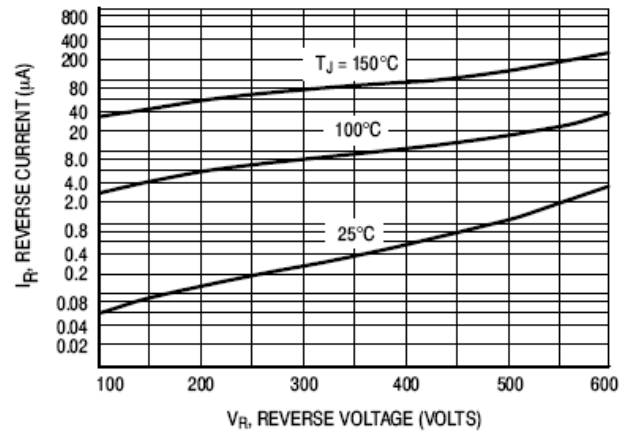

Figure 2. Typical Reverse Current Per Leg

* The curves shown are typical for the highest voltage device in the voltage grouping. Typical reverse current for lower voltage selections can be estimated from these same curves if V_R is sufficiently below rated V_R .

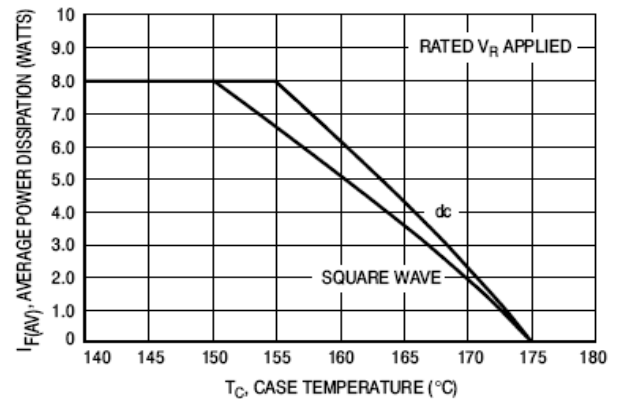

Figure 3. Current Derating, Case, Per Leg

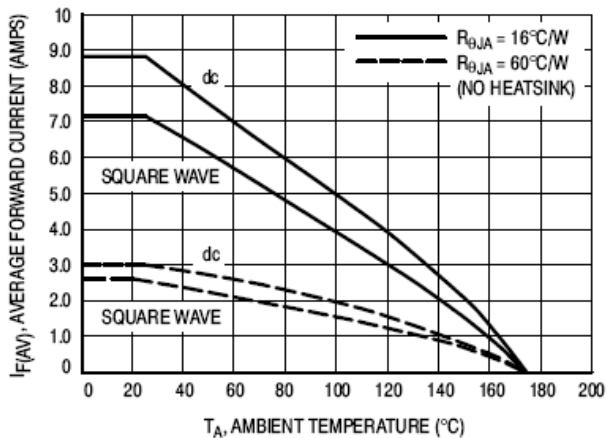

Figure 4. Current Derating, Ambient, Per Leg

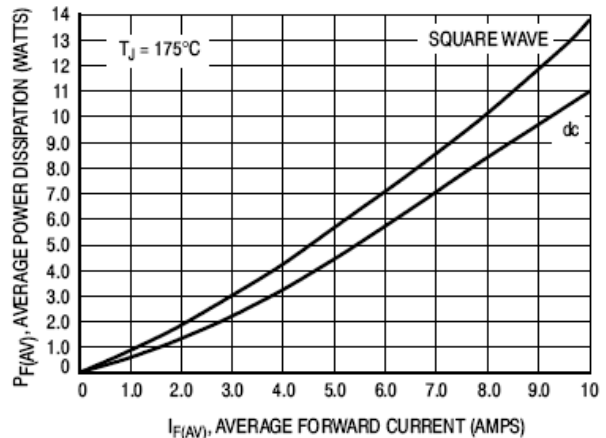

Figure 5. Power Dissipation, Per Leg

Ratings and Characteristics Curves ($T_A = 25^\circ\text{C}$ unless otherwise noted)

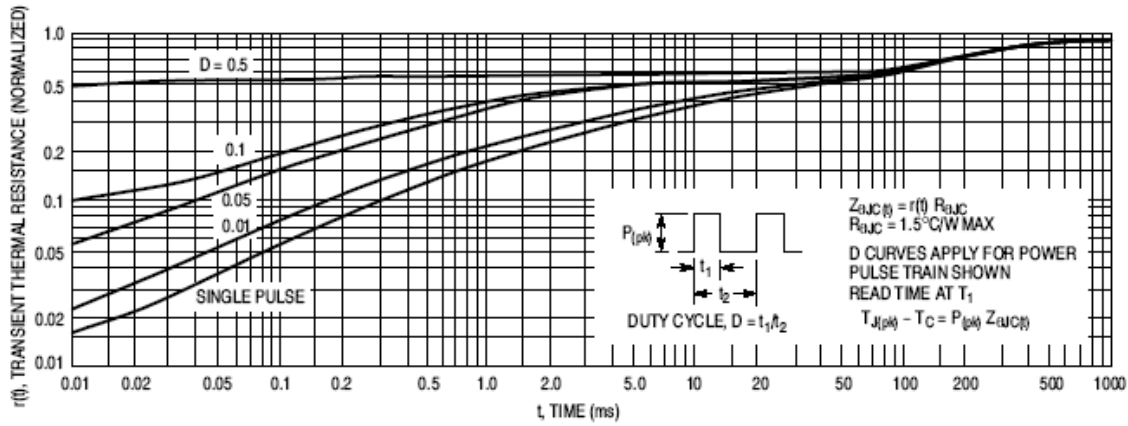

Figure 6. Thermal Response

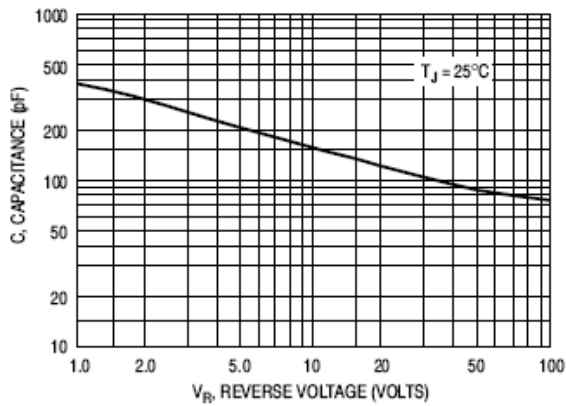

Figure 7. Typical Capacitance

MUR1060/MUR1060F

Ultrafast Recovery Rectifiers
Reverse Voltage 600V Forward Current 10 A

Package Outline Dimensions

in millimeters

TO-220-AC

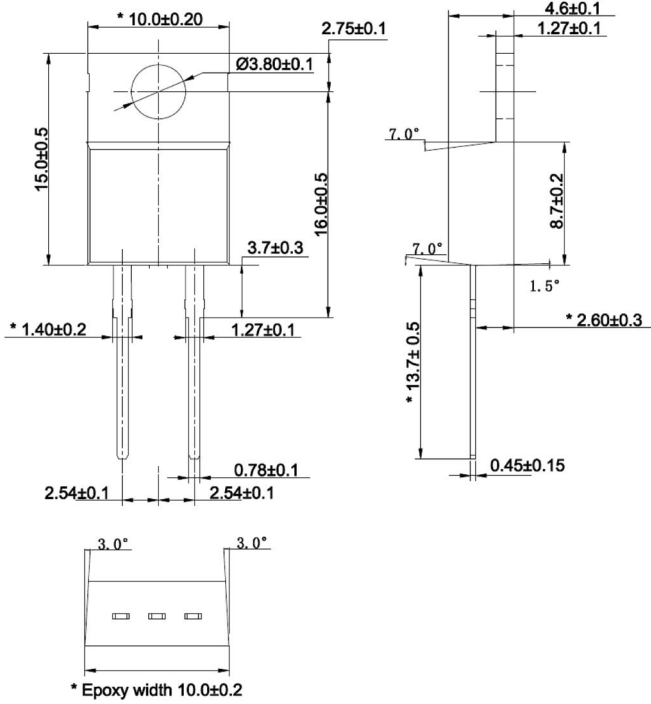

ITO-220-AC

