

MLSEP05A-0402 Multilayer Polymer ESD Suppressor

Description

This device is an ultra low capacitance PESD product designed to protect very high speed data interfaces. MLSEP05A-0402 has a typical capacitance of only 0.05pf (I/O to GND), and it can be used to meet the ESD immunity requirements of IEC 61000-4-2 (15KV air, 8KV contact discharge).



Case: 0402

Features

- ESD protection for high speed data lines to IEC61000-4-2
- ESD contact discharge typical 8KV, max 15KV
- ESD air discharge typical 15KV, max 25KV
- Multilayer structure
- Surface mount
- Extremely low capacitance
- Very low leakage current
- Fast response time
- Bi-directional ESD protection
- Lead free solder termination
- The best ESD protection for high frequency, low voltage applications

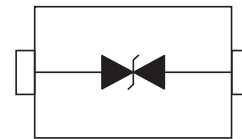

Schematic Diagram

Applications

- High Definition Multi-Media Interface (HDMI)
- Digital Visual Interface (DVI)
- Display Port Interface (DP)
- Unified Display Interface (UDI)
- Mobile Display Digital Interface (MDDI)
- Gigabit Ethernet
- USB2.0 and USB3.0
- IEEE1394 interface

Caution:

This component is designed for signal line protection only,
Not intended to be used under bias, not for application with a power line.

Multilayer Polymer ESD Suppressor

Absolute Maximum Ratings

Parameter	Symbol	Value	Unit
Maximum Contact Discharge Voltage Per IEC61000-4-2	---	15KV	V
Maximum Air Discharge Voltage Per IEC61000-4-2	---	25KV	V
Maximum Operating Temperature	T _{OPER}	-40 to +90	°C
Maximum Storage Temperature	T _{STG}	-55 to +125	°C
Maximum Lead Temperature for Soldering During 10s	T _L	260	°C

Electrical Characteristics (T_A=25°C)

Parameter	Symbol	Test Conditions	Min	Typ	Max	Units
Rated Voltage	V _R	---	---	---	5	V
Trigger Voltage	V _T	IEC61000-4-2 8KV contact discharge	---	300	---	V
Clamping Voltage	V _C	IEC61000-4-2 8KV contact discharge	---	20	---	V
Leakage Current	I _L	DC 5V shall be applied on component	---	0.10	100	nA
Capacitance	C _P	V _R = 0V, f = 1MHz	---	0.05	0.15	pF
ESD Pulse Withstand	Pulses	IEC61000-4-2 8KV contact discharge	100	---	---	---

Note: 1 Trigger and clamping voltage are measured per IEC 61000-4-2, 8KV contact discharge method.

2 After reliability tests such as high temp storage, temp cycles, continuous ESD strike etc, the maximum leakage current is less than 10uA.

ESD Clamping Test

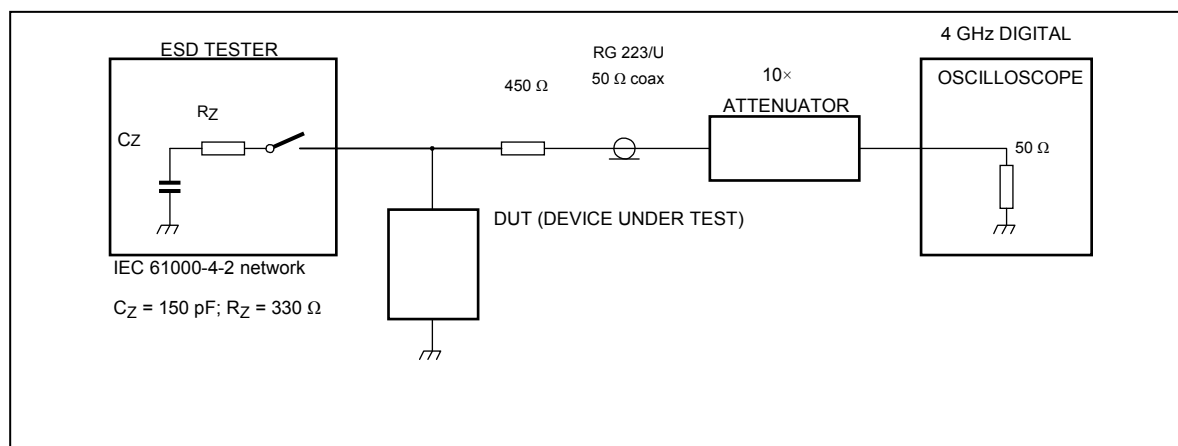

Multilayer Polymer ESD Suppressor

ESD Clamping Test Waveforms

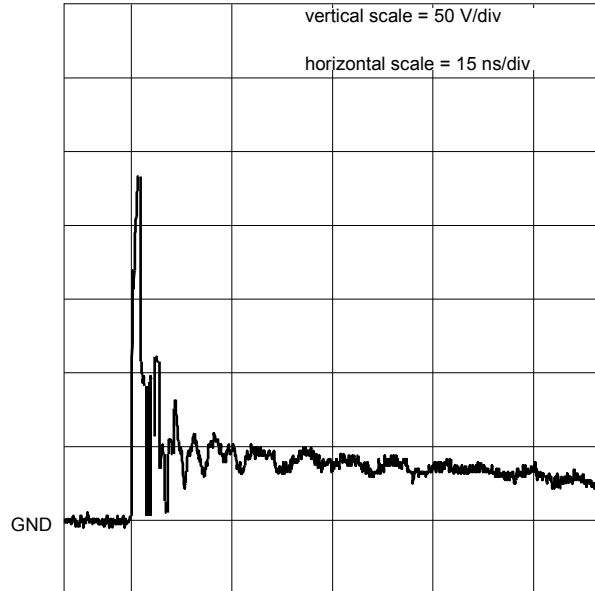
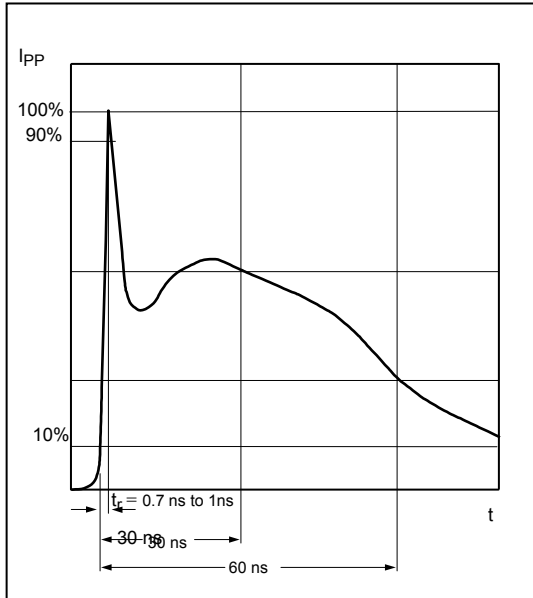

Product Dimensions

Case: 0402

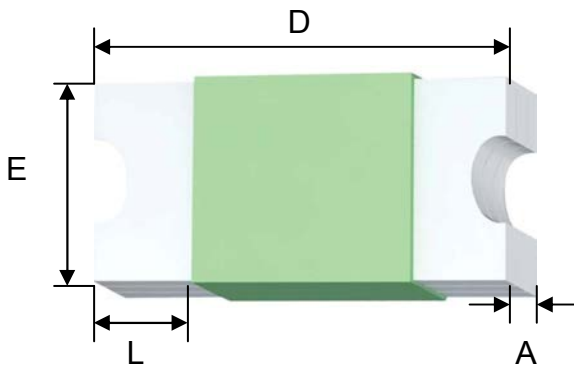

Dimension	Unit: Millimeters		
	Min	Typ	Max
D	0.90	1.05	1.20
E	0.45	0.55	0.65
L	0.15	0.25	0.35
A	0.25	0.36	0.45

PAD Dimensions

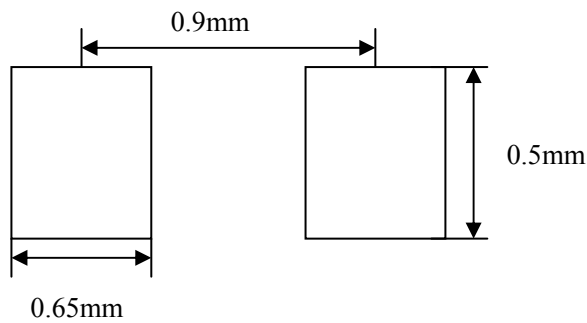

Solder thickness 0.15 to 0.2mm

Multilayer Polymer ESD Suppressor

Solder Reflow Recommendations

Ttemperatures (°C)

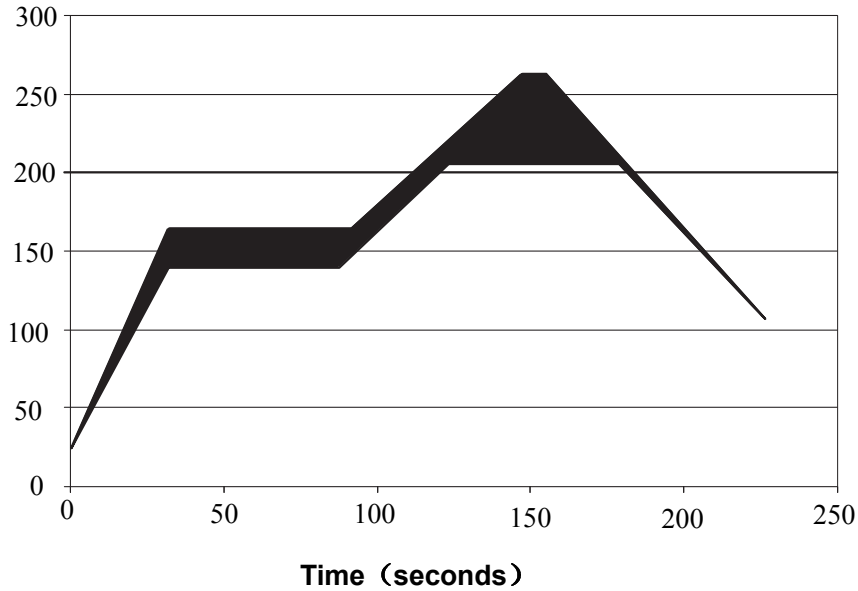

Package Information

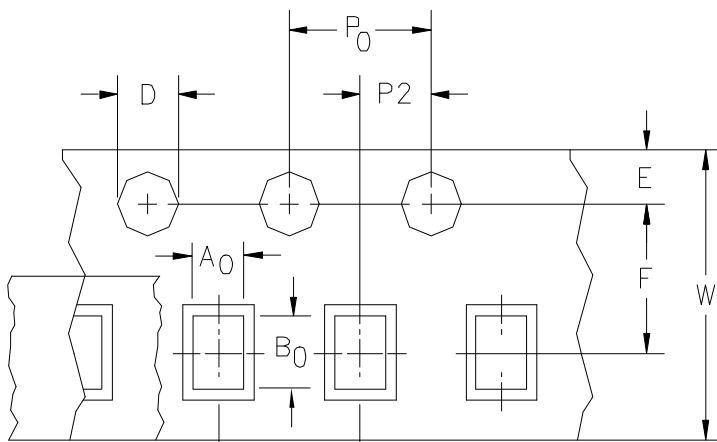

Dimension	Typical	Unit
A0	0.75	mm
B0	1.22	
D	1.55	
P0	4.00	
P1	2.00	
P2	2.00	
E	1.75	
F	3.50	
W	8.00	

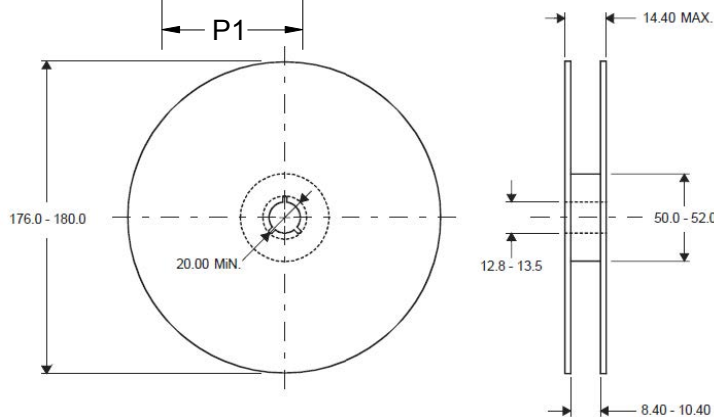

DIMENSIONS ARE: MILLIMETERS