

## Description

This device is an ultra low capacitance ESD product designed to protect very high speed data interfaces. ESDPSA0402V12 has a typical capacitance of only 0.05pf (I/O to GND), and it can be used to meet the ESD immunity requirements of IEC61000-4-2 (15KV air, 8KV contact discharge).

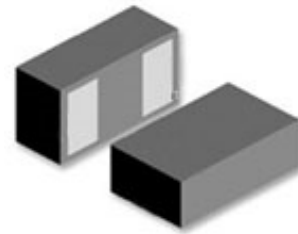

Case: 0402

## Features

- ESD protection for high speed data lines to IEC61000-4-2
- ESD contact discharge typical 8KV, max 15KV
- ESD air discharge typical 15KV, max 25KV
- Surface mount
- Extremely low capacitance
- Very low leakage current
- Fast response time
- Bi-directional ESD protection
- Lead free solder termination
- The best ESD protection for high frequency, low voltage applications

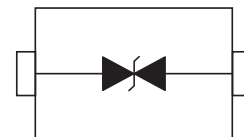

Schematic Diagram

## Applications

- High Definition Multi-Media Interface (HDMI)
- Digital Visual Interface (DVI)
- Display Port Interface (DP)
- Unified Display Interface (UDI)
- Mobile Display Digital Interface (MDDI)
- Gigabit Ethernet
- USB2.0 and USB3.0
- IEEE1394 interface

### Caution:

This component is designed for signal line protection only,  
Not intended to be used under bias, not for application with a power line.

### Absolute Maximum Ratings

Parameter	Symbol	Value	Unit
Maximum Contact Discharge Voltage Per IEC61000-4-2	---	15KV	V
Maximum Air Discharge Voltage Per IEC61000-4-2	---	25KV	V
Maximum Operating Temperature	T <sub>OPER</sub>	-40 to +90	°C
Maximum Storage Temperature	T <sub>STG</sub>	-55 to +125	°C
Maximum Lead Temperature for Soldering During 10s	T <sub>L</sub>	260	°C

### Electrical Characteristics (T<sub>A</sub>=25°C)

Parameter	Symbol	Test Conditions	Min	Typ	Max	Units
Rated Voltage	V <sub>R</sub>	---	---	---	12	V
Trigger Voltage	V <sub>T</sub>	IEC61000-4-2 8KV contact discharge	---	450	---	V
Clamping Voltage	V <sub>C</sub>	IEC61000-4-2 8KV contact discharge	---	35	---	V
Leakage Current	I <sub>L</sub>	DC 5V shall be applied on component	---		0.10	uA
Capacitance	C <sub>P</sub>	V <sub>R</sub> = 0V, f = 1MHz	---	0.05		pF

**Note:** 1 Trigger and clamping voltage are measured per IEC 61000-4-2, 8KV contact discharge method.

2 After reliability tests such as high temp storage, temp cycles, continuous ESD strike etc, the maximum leakage current is less than 10uA.

### ESD Clamping Test

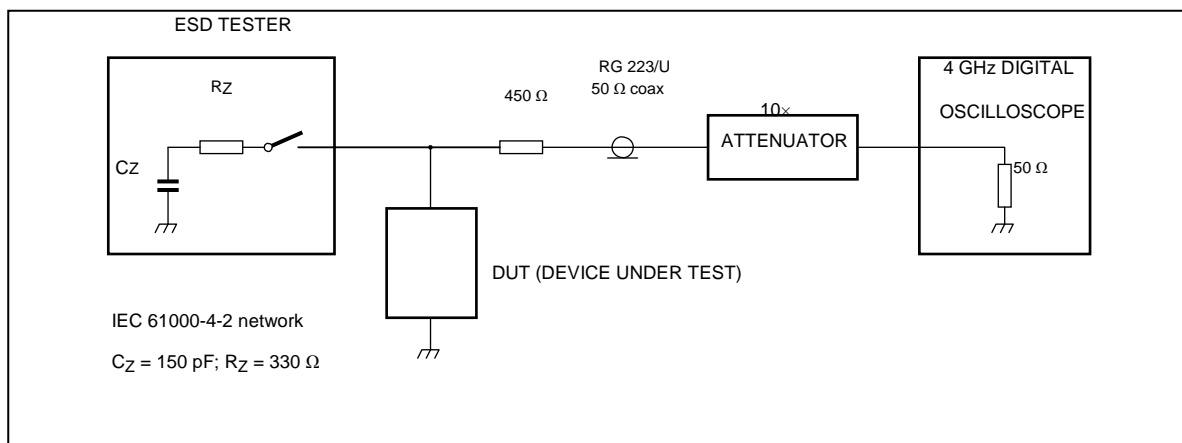

**ESD Clamping Test Waveforms**

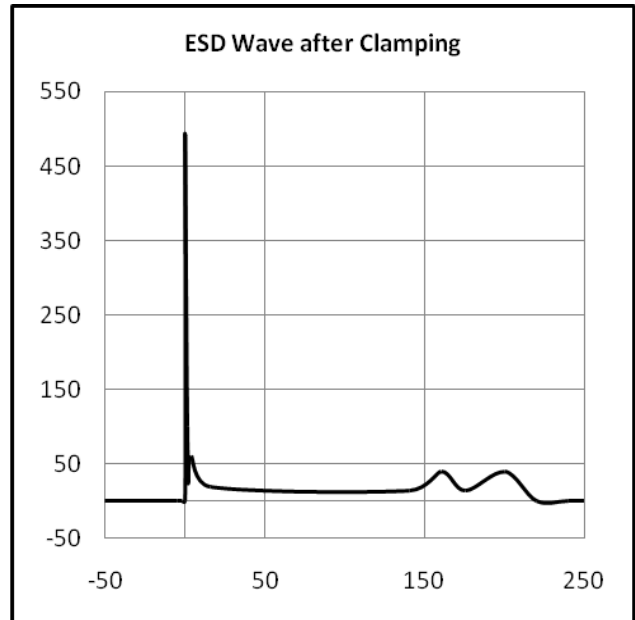
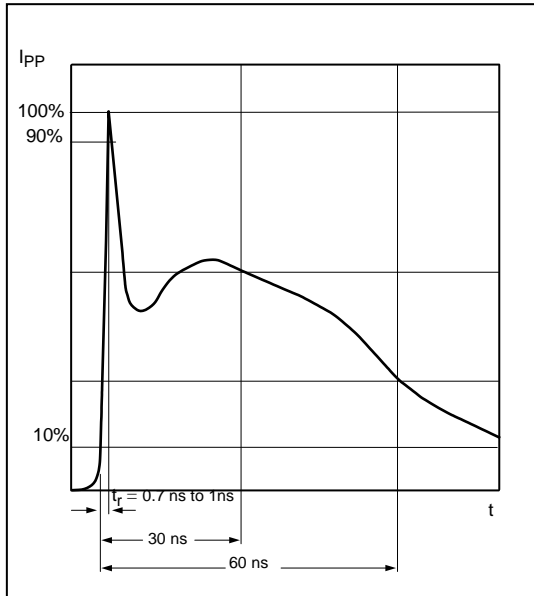

**Product Dimensions**

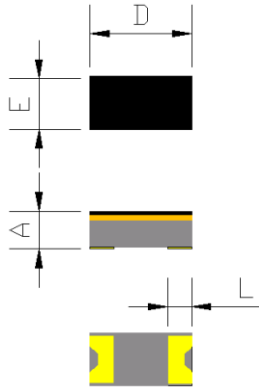

Dimension	Unit: Millimeters		
	Min	Typ	Max
<b>D</b>	0.90	1.05	1.20
<b>E</b>	0.45	0.55	0.65
<b>L</b>	0.15	0.25	0.35
<b>A</b>	0.25	0.36	0.45

**Pad Dimensions**

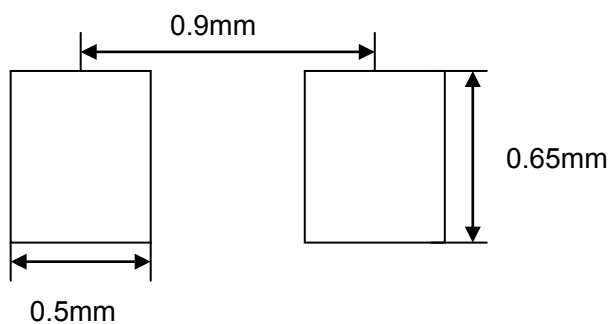

Solder thickness 0.15 to 0.2mm

**Solder Reflow Recommendations**

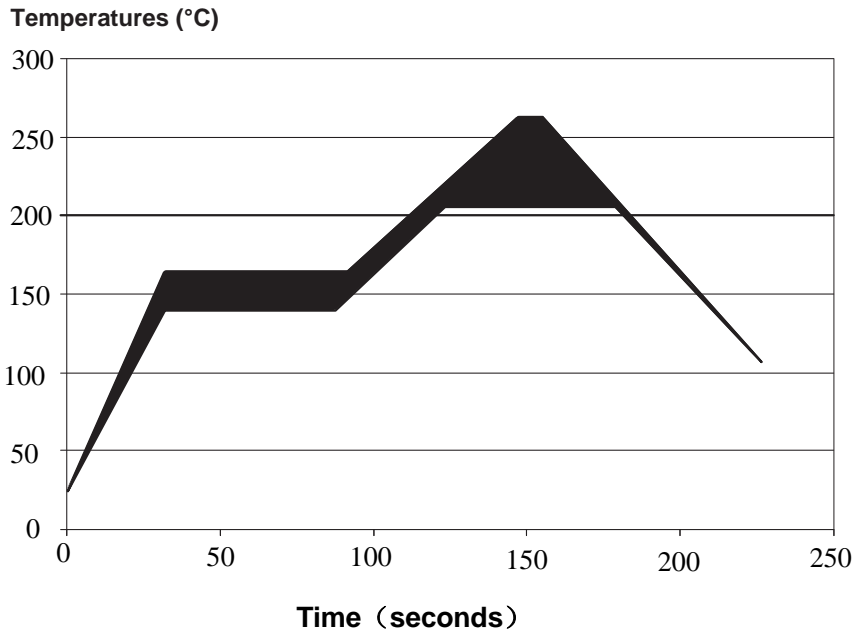

**Package Information**

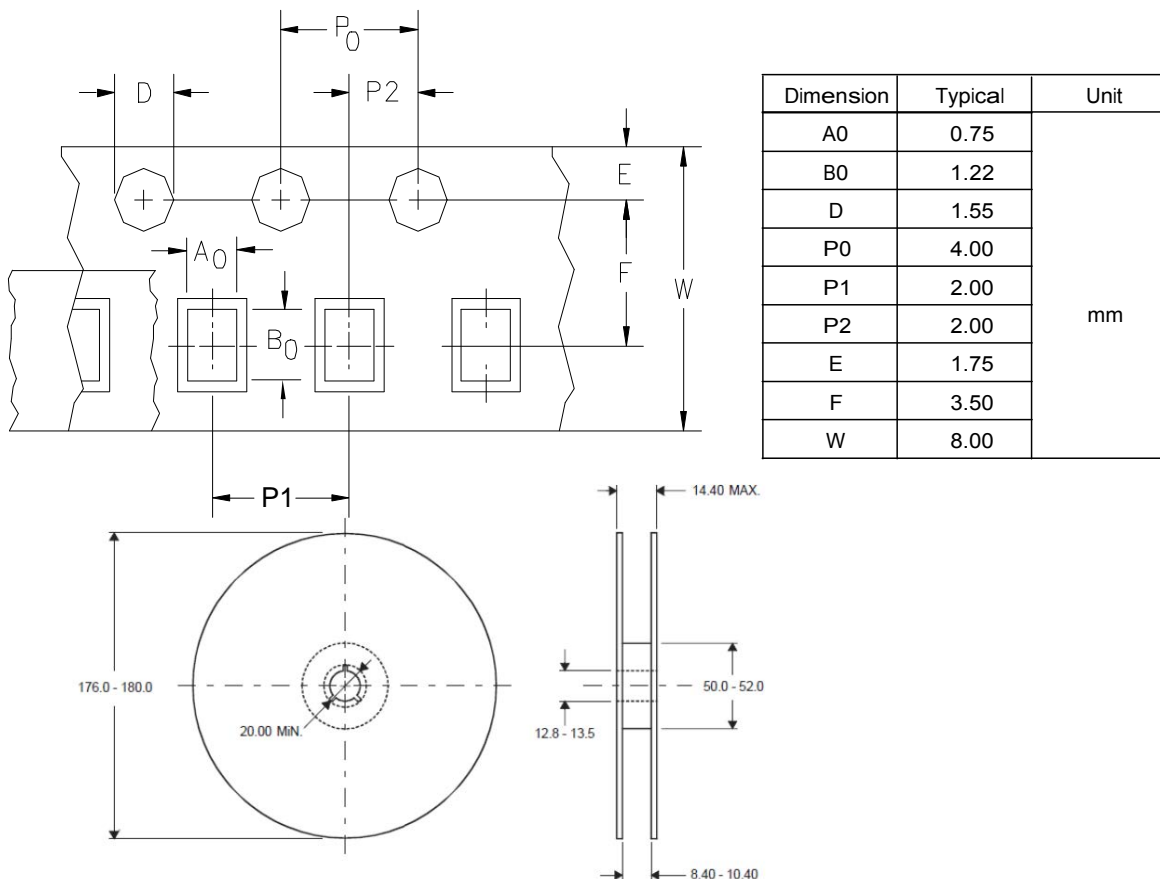

DIMENSIONS ARE: MILLIMETERS