

## Description

This device is an ultra low capacitance ESD product designed to protect very high speed data interfaces. ESDCSA0201V05 has a typical capacitance of only 0.15pf (I/O to GND), and it can be used to meet the ESD immunity requirements of IEC61000-4-2 (15KV air, 8KV contact discharge).

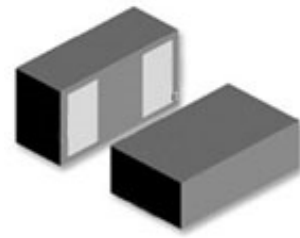

Case: 0201

## Features

- ESD protection for high speed data lines to IEC61000-4-2
- ESD contact discharge typical 8KV, max 15KV
- ESD air discharge typical 15KV, max 25KV
- Surface mount
- Extremely low capacitance
- Very low leakage current
- Fast response time
- Bi-directional ESD protection
- Lead free solder termination
- The best ESD protection for high frequency, low voltage applications

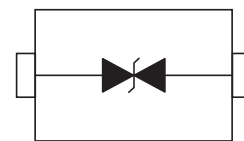

Schematic Diagram

## Applications

- High Definition Multi-Media Interface (HDMI)
- Digital Visual Interface (DVI)
- Display Port Interface (DP)
- Unified Display Interface (UDI)
- Mobile Display Digital Interface (MDDI)
- Gigabit Ethernet
- USB2.0 and USB3.0
- IEEE1394 interface

### Caution:

This component is designed for signal line protection only,  
Not intended to be used under bias, not for application with a power line.

### Absolute Maximum Ratings

Parameter	Symbol	Value	Unit
Maximum Contact Discharge Voltage Per IEC61000-4-2	---	15KV	V
Maximum Air Discharge Voltage Per IEC61000-4-2	---	25KV	V
Maximum Operating Temperature	T <sub>OPER</sub>	-40 to +90	°C
Maximum Storage Temperature	T <sub>STG</sub>	-55 to +125	°C
Maximum Lead Temperature for Soldering During 10s	T <sub>L</sub>	260	°C

### Electrical Characteristics (T<sub>A</sub>=25°C)

Parameter	Symbol	Test Conditions	Min	Typ	Max	Units
Rated Voltage	V <sub>R</sub>	---	---	---	5	V
Trigger Voltage	V <sub>T</sub>	IEC61000-4-2 8KV contact discharge	---	400	---	V
Clamping Voltage	V <sub>C</sub>	IEC61000-4-2 8KV contact discharge	---	40	---	V
Leakage Current	I <sub>L</sub>	DC 5V shall be applied on component	---		0.10	uA
Capacitance	C <sub>P</sub>	V <sub>R</sub> = 0V, f = 1MHz	---	0.15		pF

**Note:** 1 Trigger and clamping voltage are measured per IEC 61000-4-2, 8KV contact discharge method.

2 After reliability tests such as high temp storage, temp cycles, continuous ESD strike etc, the maximum leakage current is less than 10uA.

### ESD Clamping Test

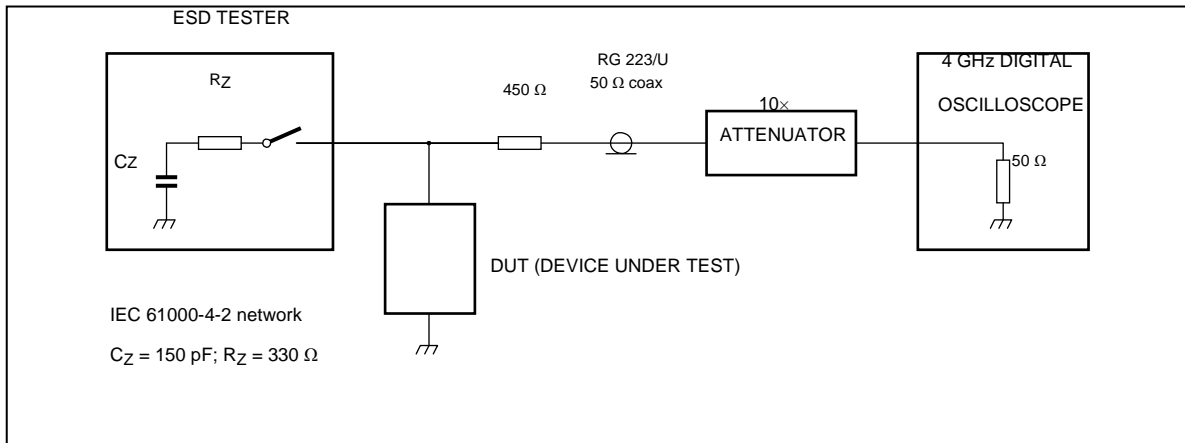

**ESD Clamping Test Waveforms**

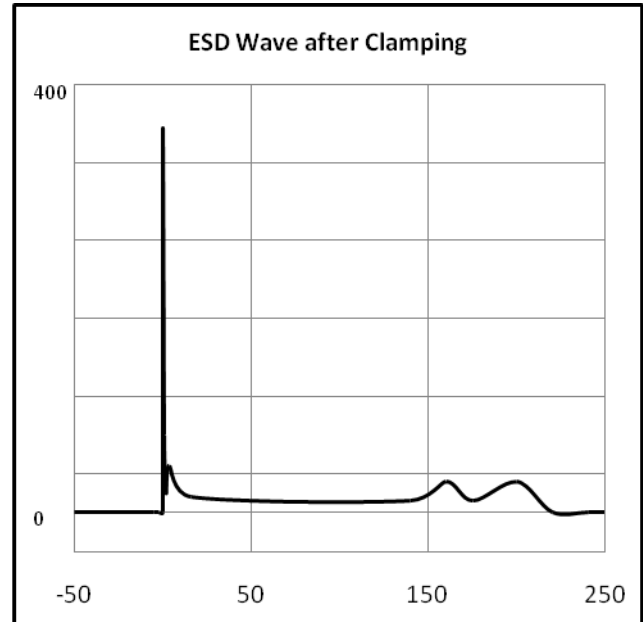
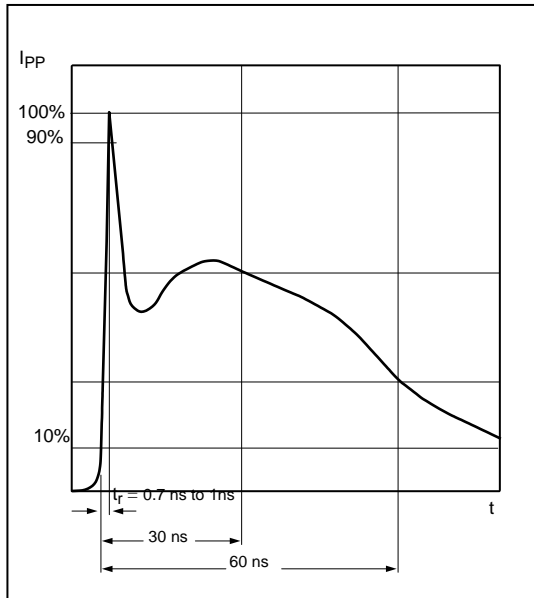

**Product Dimensions**

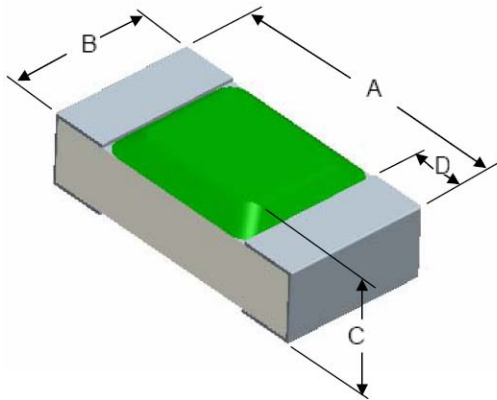

Parameter	Symbol	Dimension			Unit
		Min	Typ	Max	
Length	A	0.50	0.60	0.70	mm
Width	B	0.25	0.30	0.35	
Height	C	0.25	0.35	0.40	
*1Terminal width	D	0.10	0.20	0.30	

**Pad Dimensions**

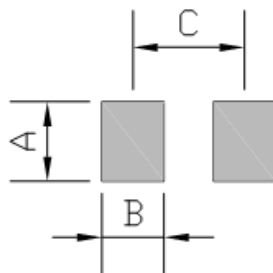

Symbol	Dimension	Unit
A	0.30	mm
B	0.25	
C	0.60	

**Solder Reflow Recommendations**

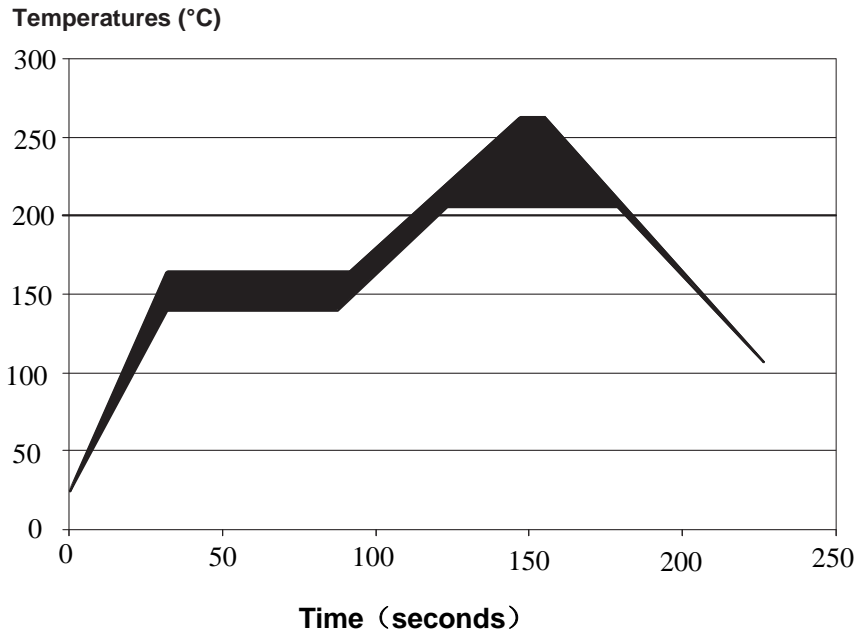

**Package Information**

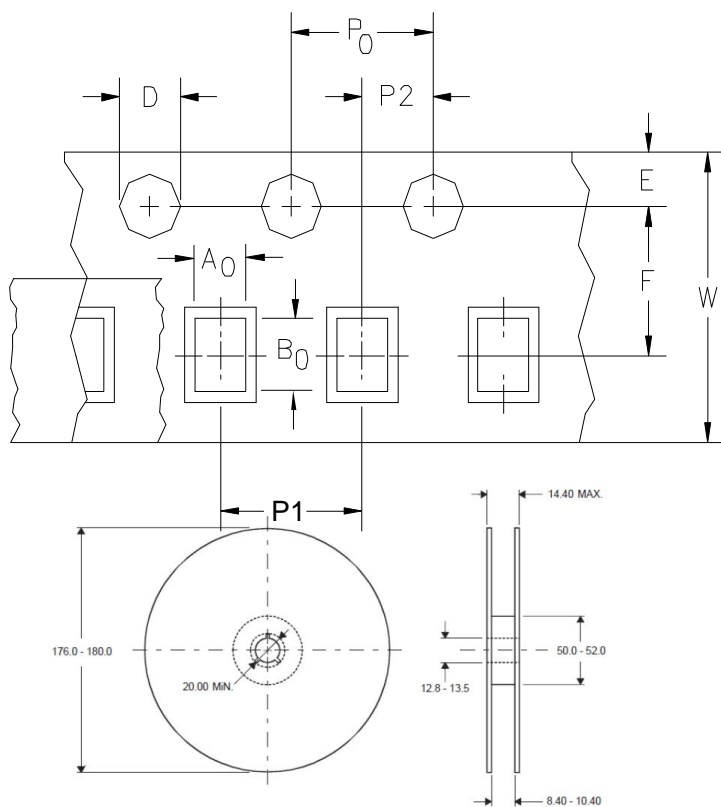

Dimension	Typical	Unit
A0	0.35	mm
B0	0.65	
D	1.50	
P0	4.00	
P1	2.00	
P2	2.00	
E	1.75	
F	3.50	
W	8.00	

DIMENSIONS ARE: MILLIMETERS