

SPP10120D1

1200V Silicon Carbide Diode

Features

- 1200-Volt Schottky Rectifier
- Shorter recovery time
- High-speed switching possible
- High-Frequency Operation
- Temperature-Independent Switching Behavior
- Extremely Fast Switching
- Positive Temperature Coefficient on VF

Benefits

- Higher safety margin against overvoltage
- Improved efficiency all load conditions
- Increased efficiency compared to Silicon Diode alternatives
- Reduction of Heat Sink Requirements
- Parallel Devices Without Thermal Runaway
- Essentially No Switching Losses

Applications

- Switch Mode Power Supplies
- Power Factor Correction
- Motor Drives
- HID Lighting

Package



Type : TO-220FB -2 1、Cathode 2、Anode



Absolute Maximum Ratings

$T_c = 25^\circ\text{C}$ unless otherwise noted

Symbol	Parameter	SPP10120D1	Units
VRRM	Repetitive Peak Reverse Voltage	1200	V
VRSM	Surge Peak Reverse Voltage	1200	V
VDC	DC Blocking Voltage	1200	V
IF	Continuous Forward Current @Tc=25°C @Tc=135°C @Tc=150°C	34 19 10	A
IFRM	Repetitive Peak Forward Surge Current @TC=25°C, tP = 10 ms, Half Sine Wave	50	A
IFSM	Non-Repetitive Peak Forward Surge Current @TC=25°C, tP = 10 ms, Half Sine Wave	70	A
Ptot	Power Dissipation @Tc=25°C @Tc=110°C	205 90	W
TJ , Tstg	Operating Junction and Storage Temperature	-55 to +175	°C

Electrical Characteristics

$T_C = 25^\circ \text{C}$ unless otherwise noted

Symbol	Test Conditions	Test Conditions	Min	Typ	Max	Unit
VF	Forward Voltage	IF=6A, TC=25° C IF=6A, TC=175° C	-	1.5 2.2	1.8 3.0	V
IR	Reverse Current	VR=1200V, TC=25° C VR=1200V, TC=175° C	-	10 50	100 400	μA
QC	Total Capacitive Charge	VR =600V, IF =10A TJ = 25° C $Q_c = \int_0^{V_r} C (V) dv$	-	50	-	nC
C	Total Capacitance	VR =0V, TJ = 25° C, f=1MHz VR =400V, TJ = 25° C, f=1MHz VR =600V, TJ = 25° C, f=1MHz	-	610 46 40	-	pF
EC	Capacitance Stored Energy	VR=600V	-	15	-	μJ

Thermal Characteristics

Symbol	Parameter	Typ	Unit
RθJC	Thermal Resistance from Junction to Case	0.73	°C/W

Typical Characteristics

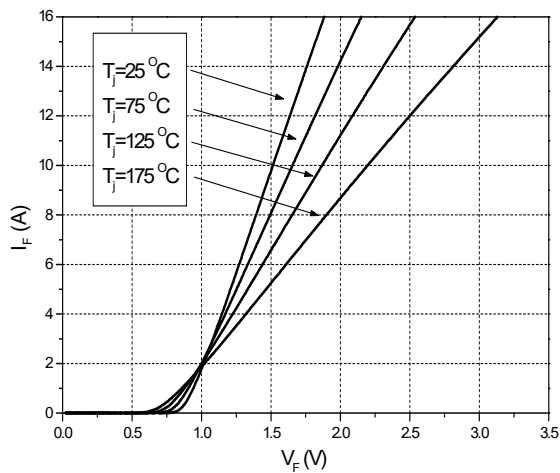

Figure 1. Forward Characteristics

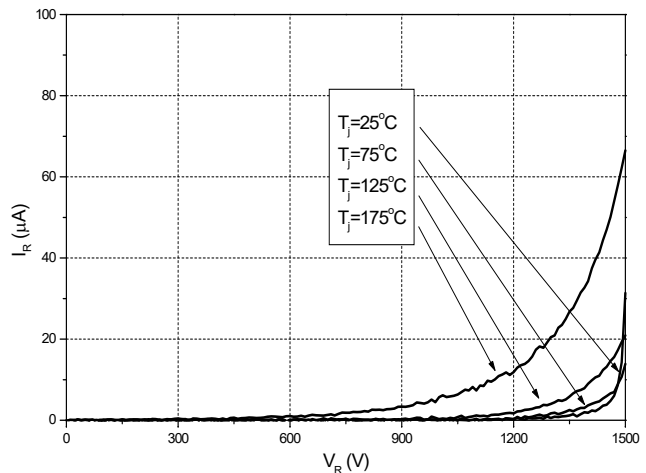

Figure 2. Reverse Characteristics

Typical Characteristics

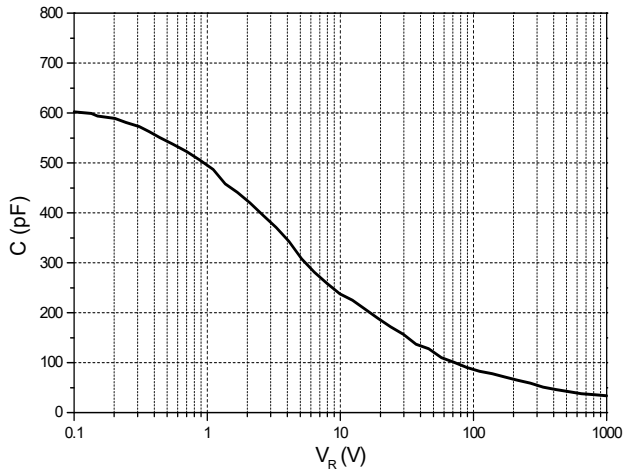

Figure 3. Capacitance vs. Reverse Voltage

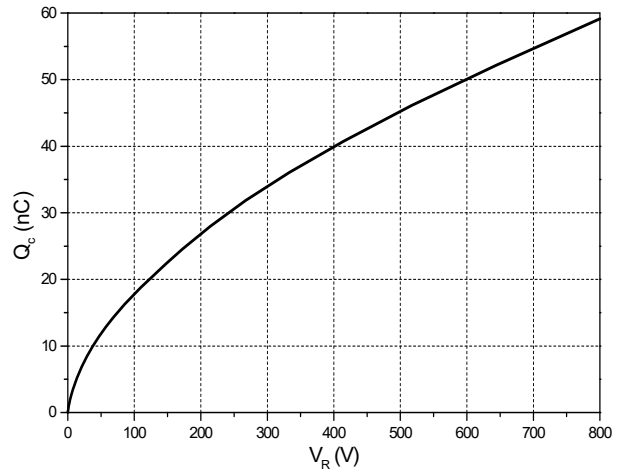

Figure 4. Total Capacitance Charge vs. Reverse Voltage

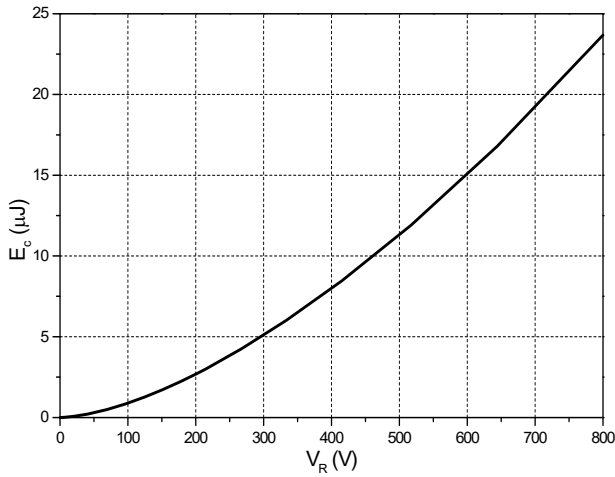

Figure 5. Capacitance Stored Energy

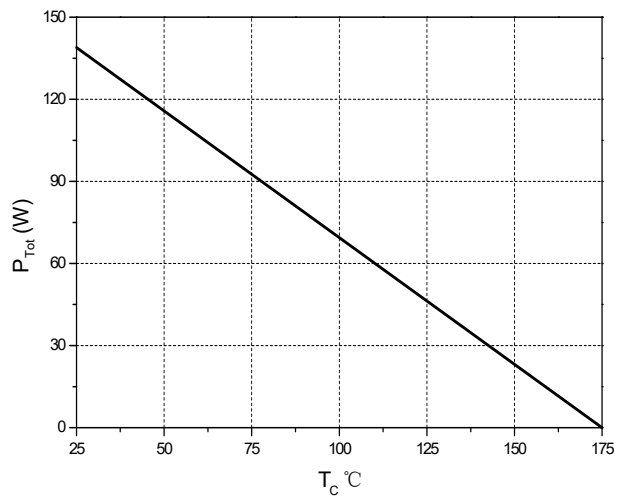

Figure 6. Power Derating

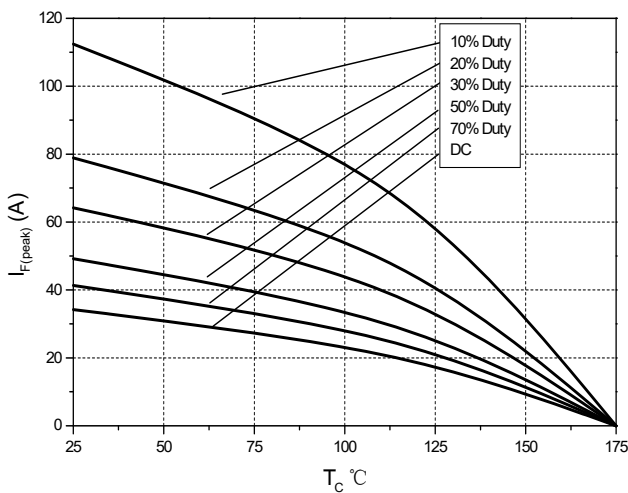

Figure 7. Current Derating

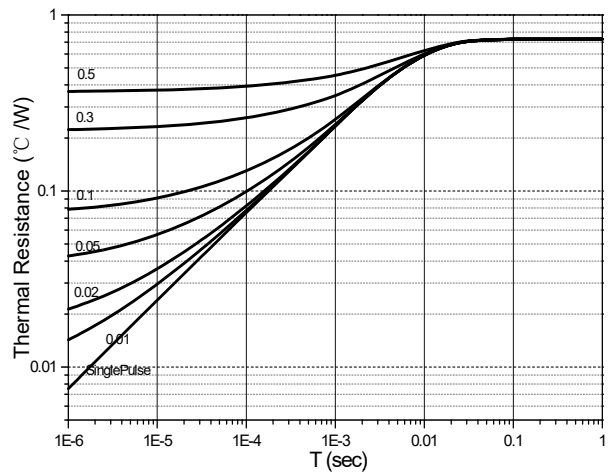
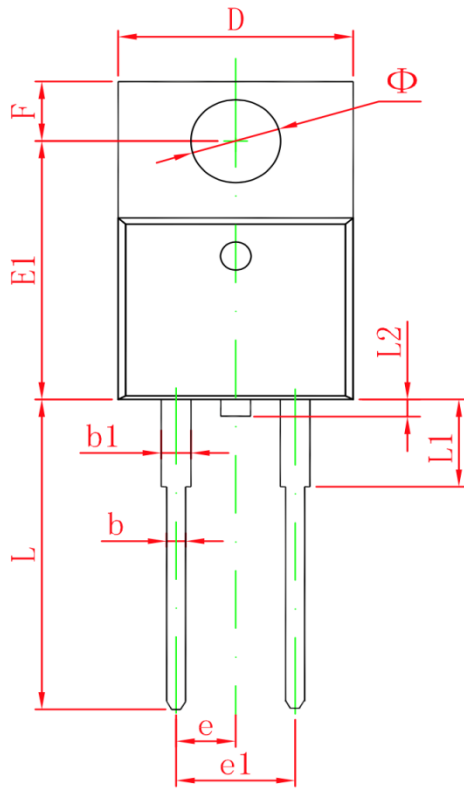

Figure 8. Transient Thermal Impedance

Package Dimensions



Symbol	Dimensions In Millimeters		Dimensions In Inches	
	Min	Max	Min	Max
A	4.470	4.670	0.176	0.184
A1	2.520	2.820	0.099	0.111
b	0.710	0.910	0.028	0.036
b1	1.170	1.370	0.046	0.054
c	0.310	0.530	0.012	0.021
c1	1.170	1.370	0.046	0.054
D	10.010	10.310	0.394	0.406
E	8.500	8.900	0.335	0.350
E1	12.060	12.460	0.475	0.491
e	2.540 TYP		0.100 TYP	
e1	4.980	5.180	0.196	0.204
F	2.590	2.890	0.102	0.114
h	0.000	0.300	0.000	0.012
L	13.400	13.800	0.528	0.543
L1	3.560	3.960	0.140	0.156
L2		1.000		0.039
Φ	3.735	3.935	0.147	0.155

