

Features

- Low forward voltage drop
- Fast switching
- PN junction guard ring for transient and ESD protection

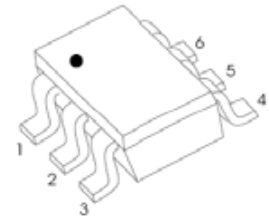

Schematic Diagram and Marking

SOT-363

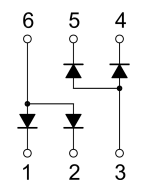
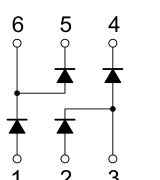
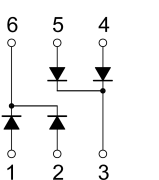
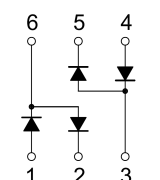
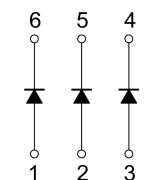
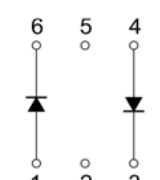
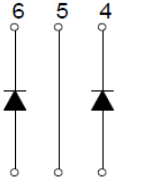
<p>SPBAT54ADW</p>  <p>Marking: KL6</p>	<p>SPBAT54BRW</p>  <p>Marking: KLB</p>	<p>SPBAT54CDW</p>  <p>Marking: KL7</p>	<p>SPBAT54SDW</p>  <p>Marking: KL8</p>	<p>SPBAT54TW</p>  <p>Marking: KLA</p>
<p>SPBAT54DW</p>  <p>Marking: KLD</p>	<p>SPBAT54JW</p>  <p>Marking: KLC</p>			

Absolute Maximum Ratings ($T_A=25^\circ\text{C}$ unless otherwise noted)

Parameter	Symbol	Value	Unit
Repetitive Peak Reverse Voltage	V_{RRM}	30	V
Peak Working Reverse Voltage	V_{RWM}	30	V
DC Blocking Voltage	V_R	30	V
Forward Continuous Current	I_o	200	mA
Repetitive Peak Forward Current	I_{FRM}	300	mA
Non-repetitive Peak Forward Surge Current @ $t=8.3\text{ms}$	I_{FSM}	600	mA
Power Dissipation	P_D	200	mW
Thermal Resistance From Junction To Ambient	$R_{\theta JA}$	500	$^\circ\text{C}/\text{W}$
Junction Temperature	T_J	125	$^\circ\text{C}$
Storage Temperature	T_{STG}	-55 to +150	$^\circ\text{C}$

Electrical Characteristics ($T_A=25^\circ\text{C}$ unless otherwise noted)

Parameter	Symbol	Test conditions	Min	Max	Unit
Reverse Voltage	$V_{(BR)}$	$I_R=100\mu\text{A}$	30	-	V
Reverse Current	I_R	$V_R=25\text{V}$	-	2	μA
Forward Voltage	V_F	$I_F=1\text{mA}$	-	320	mV
		$I_F=10\text{mA}$	-	400	
		$I_F=30\text{mA}$	-	500	
		$I_F=100\text{mA}$	-	1000	
Total Capacitance	C_{tot}	$V_R=1\text{V}, f=1\text{MHz}$	-	10	pF
Reverse Recovery Time	t_{rr}	$I_F=I_R=10\text{mA}, I_{rr}=0.1 \times I_R, R_L=100\Omega$	-	5	ns

Typical Electrical Characteristic Curves

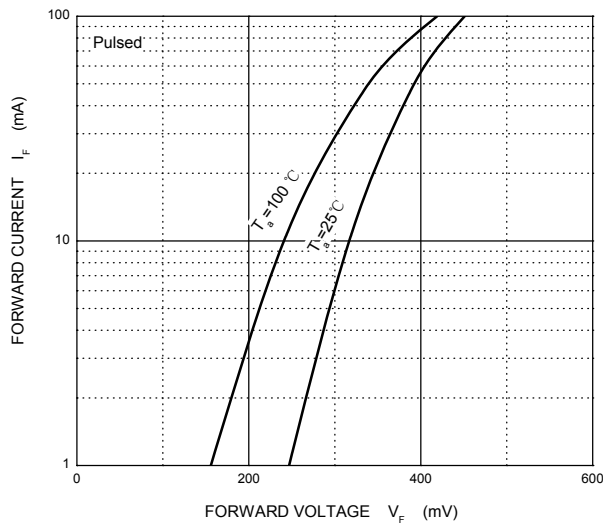

Figure 1. Forward Characteristics

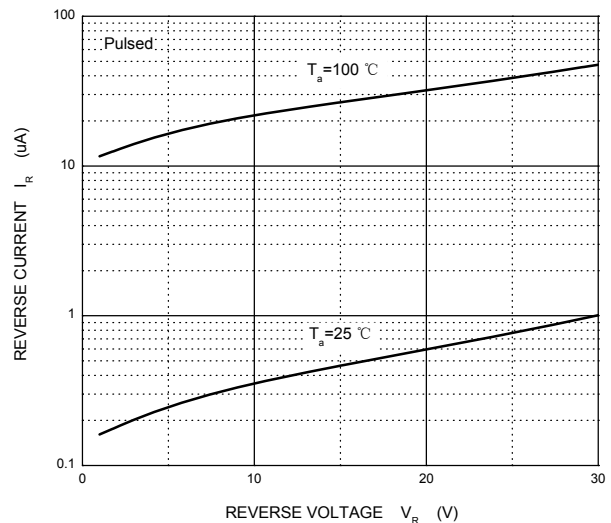

Figure 2. Reverse Characteristics

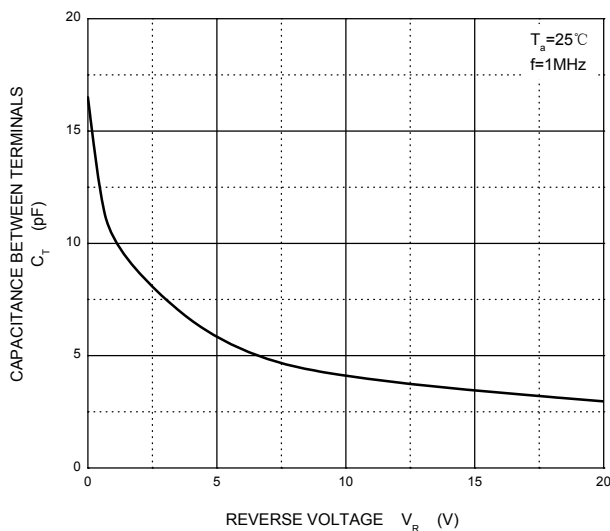

Figure 3. Capacitance Characteristics

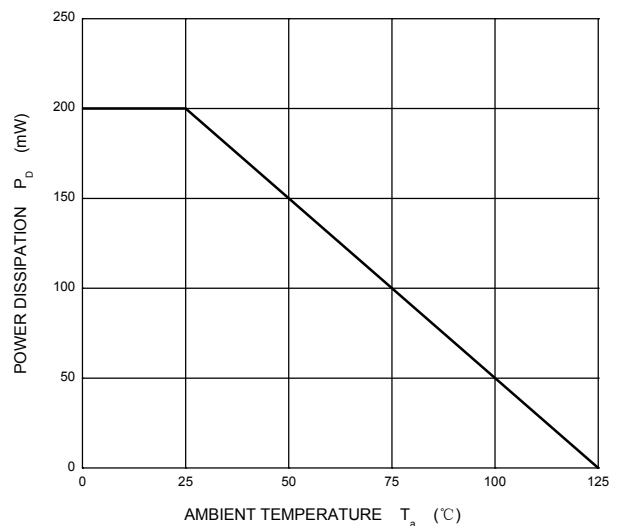
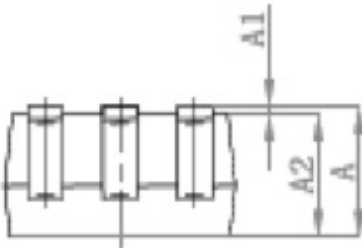
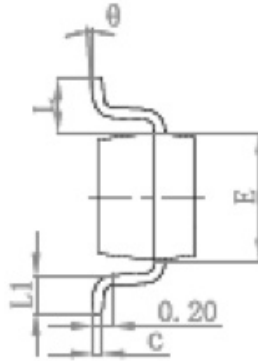

Figure 4. Power Derating Curve

Package Outline Dimensions

SOT-363



Symbol	Dimensions In Millimeters		Dimensions In Inches	
	Min	Max	Min	Max
A	0.900	1.100	0.035	0.043
A1	0.000	0.100	0.000	0.004
A2	0.900	1.000	0.035	0.039
b	0.150	0.350	0.006	0.014
c	0.100	0.150	0.004	0.006
D	2.000	2.200	0.079	0.087
E	1.150	1.350	0.045	0.053
E1	2.150	2.400	0.085	0.094
e	0.650 TYP		0.026 TYP	
e1	1.200	1.400	0.047	0.055
L	0.525 REF		0.021 REF	
L1	0.260	0.460	0.010	0.018
theta	0°	8°	0°	8°

Suggested Pad Layout

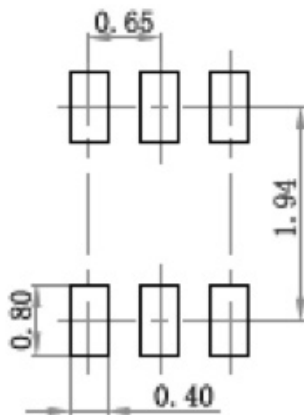

Note:

1. Controlling dimension: in millimeters.
2. General tolerance: $\pm 0.05\text{mm}$.
3. The pad layout is for reference purposes only.