

## Features

- Low forward voltage drop
- Fast switching

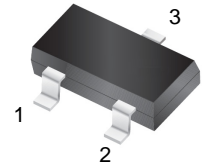

SOT-323

## Schematic Diagram and Marking

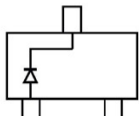

SPBAT54KW  
Marking: KL5

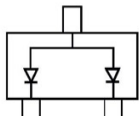

SPBAT54KAW  
Marking: KL6

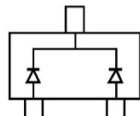

SPBAT54KCW  
Marking: KL7

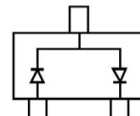

SPBAT54KSW  
Marking: KL8



## Absolute Maximum Ratings (T<sub>A</sub>=25°C unless otherwise specified)

Parameter	Symbol	Value	Unit
Peak Repetitive Reverse Voltage	V <sub>RRM</sub>	30	V
Working Peak Reverse Voltage	V <sub>RWM</sub>		
DC Blocking Voltage	V <sub>R</sub>		
Forward Continuous Current	I <sub>FM</sub>	200	mA
Non-repetitive Peak Forward Surge Current @t=8.3ms	I <sub>FSM</sub>	600	mA
Repetitive Peak Forward Current @ t≤1s, δ ≤0.5	I <sub>FRM</sub>	300	mA
Power Dissipation	P <sub>D</sub>	200	mW
Thermal Resistance from Junction to Ambient	R <sub>θJA</sub>	500	°C/W
Junction Temperature	T <sub>J</sub>	125	°C
Storage Temperature	T <sub>STG</sub>	-55 to +150	°C

## Electrical Characteristics (T<sub>A</sub>=25°C unless otherwise specified)

Parameter	Symbol	Test conditions	Min	Max	Unit
Reverse Voltage	V <sub>(BR)</sub>	I <sub>R</sub> =100μA	30	-	V
Reverse Current	I <sub>R</sub>	V <sub>R</sub> =25V	-	2	μA
Forward Voltage	V <sub>F</sub>	I <sub>F1</sub> =0.1mA	-	0.24	V
		I <sub>F2</sub> =1mA	-	0.32	V
		I <sub>F3</sub> =10mA	-	0.40	V
		I <sub>F4</sub> =30mA	-	0.50	V
		I <sub>F5</sub> =100mA	-	1	V
Diode Capacitance	C <sub>D</sub>	V <sub>R</sub> =0V, f=1MHz	-	10	pF
Reverse Recovery Time	t <sub>rr</sub>	I <sub>F</sub> =I <sub>R</sub> =10mA I <sub>rr</sub> =0.1×I <sub>R</sub> , R <sub>L</sub> =100Ω	-	5	ns

**Typical Characteristic Curves**

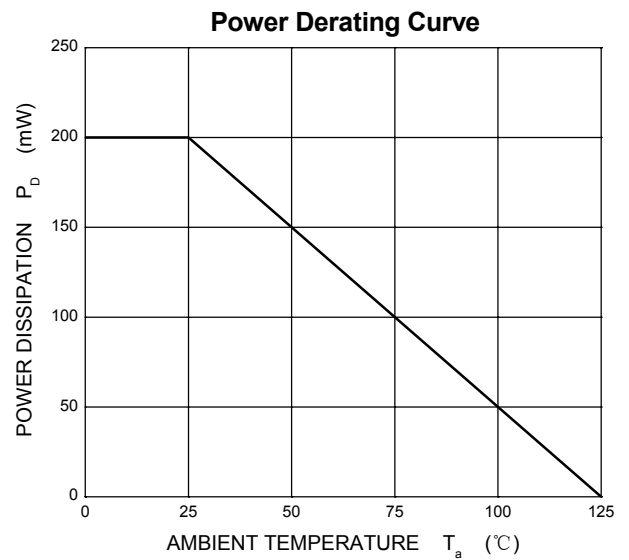
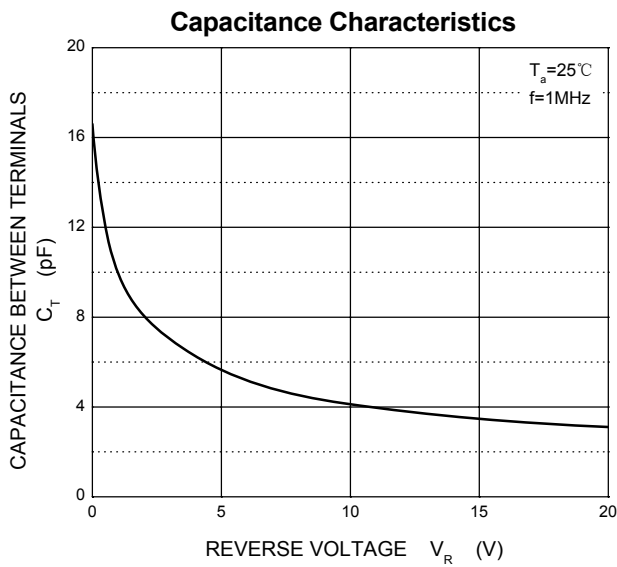
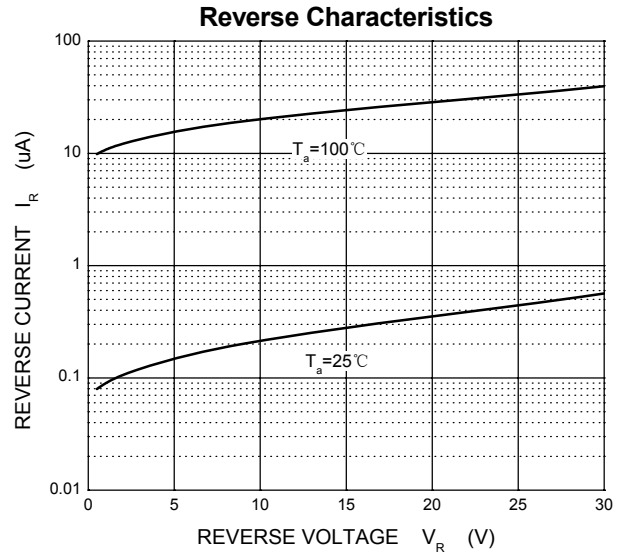
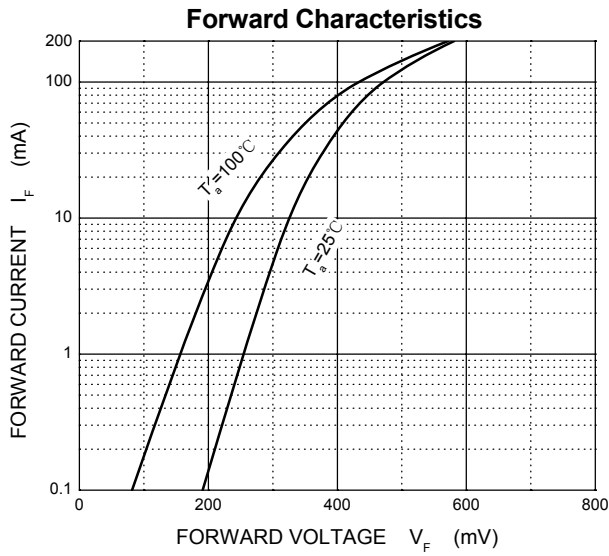

**Product Outline Dimensions**

**SOT-323**

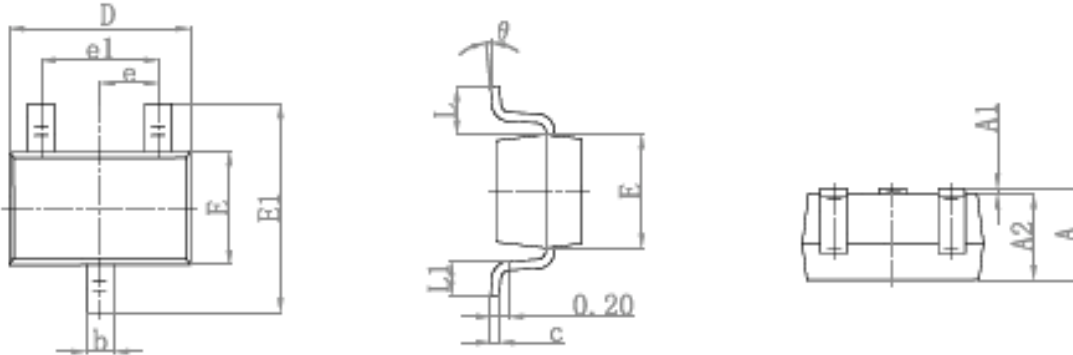

Symbol	Dimensions In Millimeters		Dimensions In Inches	
	Min	Max	Min	Max
A	0.900	1.100	0.035	0.043
A1	0.000	0.100	0.000	0.004
A2	0.900	1.000	0.035	0.039
b	0.200	0.400	0.008	0.016
c	0.080	0.150	0.003	0.006
D	2.000	2.200	0.079	0.087
E	1.150	1.350	0.045	0.053
E1	2.150	2.450	0.085	0.096
e	0.650 TYP		0.026 TYP	
e1	1.200	1.400	0.047	0.055
L	0.525 REF		0.021 REF	
L1	0.260	0.460	0.010	0.018
θ	0°	8°	0°	8°

**Suggested Pad Layout**

**SOT-323**

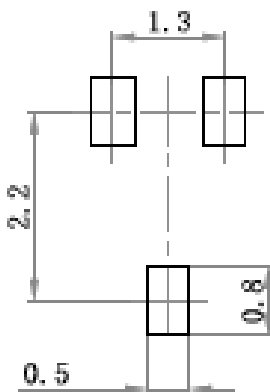

Note:

1. Controlling dimension: in millimeters.
2. General tolerance:  $\pm 0.05$ mm.
3. The pad layout is for reference purposes only.