

P-Channel Enhancement Mode Field Effect Transistor

Feature

- $V_{DS} = -15V, I_D = -3.8A$
- $R_{DS(ON)} < 52m\Omega @ V_{GS} = -4.5V$
- $R_{DS(ON)} < 78m\Omega @ V_{GS} = -2.5V$
- Epoxy meets UL 94 V-0 flammability rating
- Moisture Sensitivity Level1
- High density cell design for low $R_{DS(ON)}$
- High Speed switching
- Rugged and reliable
- SOT-23 Package

Application

- Battery protection
- Load switch
- Power management

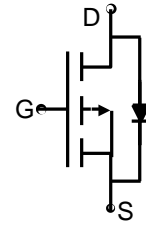

Schematic diagram

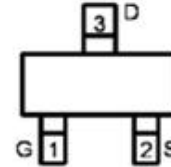

Marking and pin Assignment



SOT23 top view

■ Maximum Ratings ($T_A = 25^\circ C$ unless otherwise noted)

Symbol	Parameter	Value	Unit
V_{DS}	Drain-source Voltage	-15	V
V_{GS}	Gate-source Voltage	± 10	V
I_D	Drain Current	-3.8	A
P_D	Total Power Dissipation	1	W
R_{thJA}	Thermal Resistance From Junction To Ambient	125	$^\circ C/W$
T_J	Operation Junction Temperature	-55~+150	$^\circ C$
T_{STG}	Storage Temperature	-55~+150	$^\circ C$

■ Ordering Information

PREFERRED P/N	PACKING CODE	Marking	MINIMUM PACKAGE(pcs)	INNER BOX QUANTITY(pcs)	OUTER CARTON QUANTITY(pcs)	DELIVERY MODE
SP2301D	F2		3000	30000	120000	7" reel

■ Electrical Characteristics (TA=25°C unless otherwise specified)

Parameter	Symbol	Test conditions	Min	Typ	Max	Unit
Static Characteristics						
Drain-source breakdown voltage	$V_{(BR)DSS}$	$V_{GS}=0V, I_D=-250\mu A$	-15	-19		V
Zero gate voltage drain current	I_{DSS}	$V_{DS}=-15V, V_{GS}=0V$			-1	μA
Gate-body leakage current	I_{GSS}	$V_{GS}=\pm 10V, V_{DS}=0V$			± 100	nA
Gate threshold voltage*	$V_{GS(th)}$	$V_{DS}=V_{GS}, I_D=-250\mu A$	-0.4	-0.7	-1.0	V
Drain-source on-resistance*	$R_{DS(ON)}$	$V_{GS}=-4.5V, I_D=-3.8A$		40	52	m Ω
		$V_{GS}=-2.5V, I_D=-3.0A$		52	78	
Forward Transconductance	g_{FS}	$V_{DS}=-5V, I_D=-3.8A$	5			s
Dynamic Characteristics **						
Input Capacitance	C_{iss}	$V_{DS}=-10V, V_{GS}=0V, f=1MHz$		478		pF
Output Capacitance	C_{oss}			81		
Reverse Transfer Capacitance	C_{rss}			52		
Switching Characteristics**						
Turn-on delay time	$t_{d(on)}$	$V_{DD}=-10V, V_{GS}=-4.5V, R_L=2.8\Omega, I_D=-1A, R_{GEN}=6\Omega$		12		ns
Turn-on rise time	t_r			54		
Turn-off delay time	$t_{d(off)}$			15		
Turn-off Fall time	t_f			9		
Total Gate Charge	Q_g	$V_{DS}=-10V, I_D=-3.8A, V_{GS}=-4.5V$		4.3		nC
Gate-Source Charge	Q_{gs}			0.8		
Gate-Drain Charge	Q_{gd}			1.1		
Source-Drain Diode characteristics						
Drain-Source Diode Forward Current	I_S				-3.8	A
Diode Forward voltage	V_{SD}	$V_{GS}=0V, I_S=-3.8A$		-0.8	-1.2	V

Notes:

 *Pulse Test: Pulse Width $\leq 300\mu A$, Duty Cycle $\leq 2\%$.

**These parameters have no way to verify.

■ Characteristics (Typical)

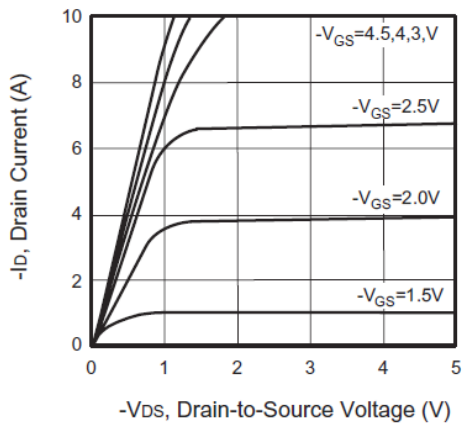

Figure 1. Output Characteristics

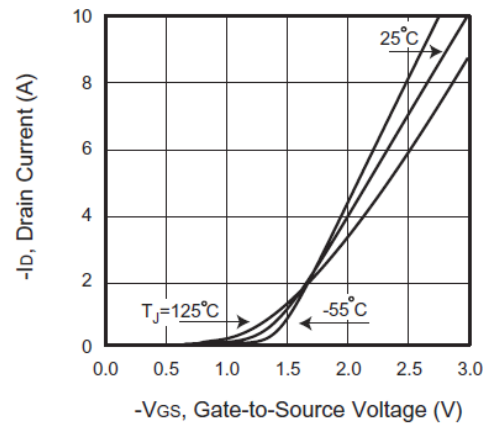

Figure 2. Transfer Characteristics

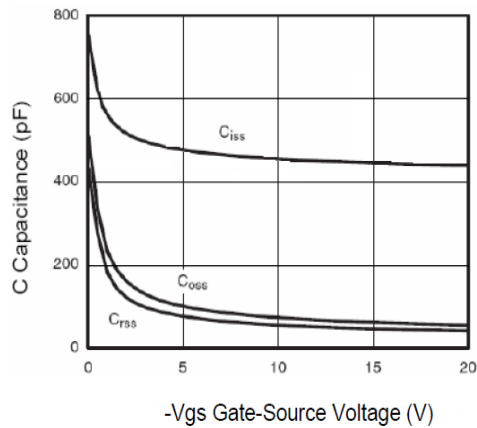

Figure 3. Capacitance

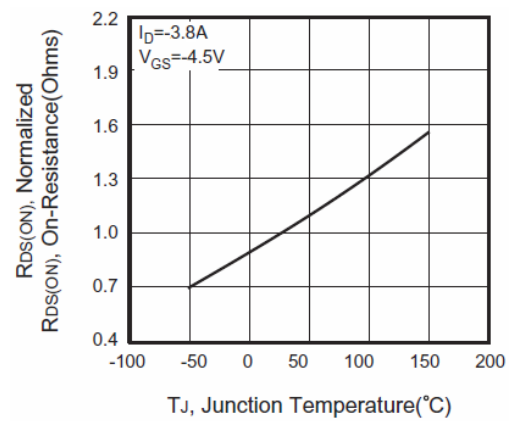

Figure 4. On-Resistance Variation with Temperature

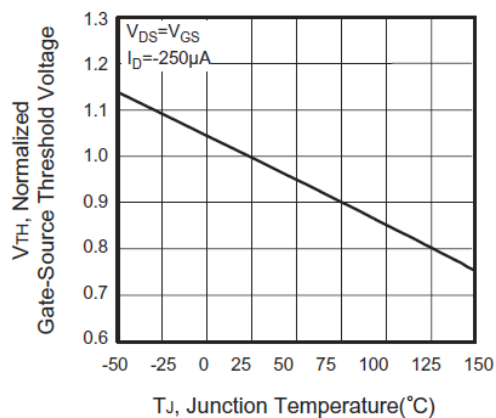

Figure 5. Gate Threshold Variation with Temperature

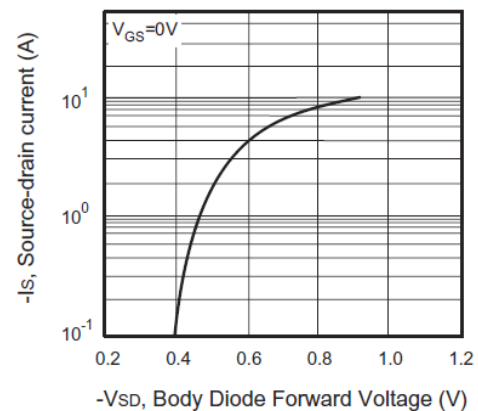
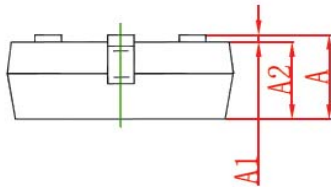
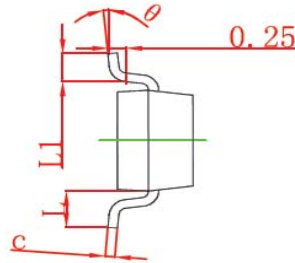
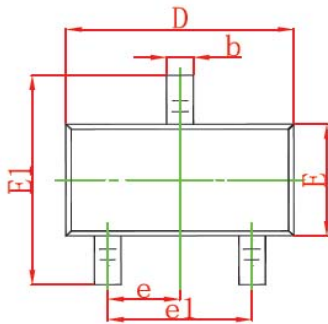

Figure 6. Body Diode Forward Voltage Variation with Source Current

■ SOT-23 Package Outline Dimensions



Symbol	Dimensions In Millimeters		Dimensions In Inches	
	Min	Max	Min	Max
A	0.900	1.150	0.035	0.045
A1	0.000	0.100	0.000	0.004
A2	0.900	1.050	0.035	0.041
b	0.300	0.500	0.012	0.020
c	0.080	0.150	0.003	0.006
D	2.800	3.000	0.110	0.118
E	1.200	1.400	0.047	0.055
E1	2.250	2.550	0.089	0.100
e	0.950 TYP		0.037 TYP	
e1	1.800	2.000	0.071	0.079
L	0.550 REF		0.022 REF	
L1	0.300	0.500	0.012	0.020
θ	0°	8°	0°	8°

■ SOT-23 Suggested Pad Layout

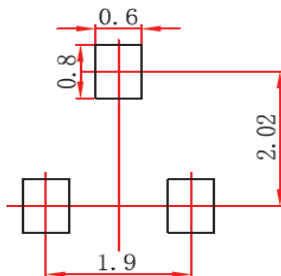

- Note:
1. Controlling dimension: in millimeters.
 2. General tolerance: $\pm 0.05\text{mm}$.
 3. The pad layout is for reference purposes only.

Disclaimers

These materials are intended as a reference to assist our customers in the selection of the Steifpower Technology products best suited to the customer's applications, they do not convey any license under any intellectual property rights, or any other rights, belonging to Steifpower Technology or third party. Steifpower Technology assumes no responsibility for any damage, or infringement of any third-party's rights, originating in the use of any product data, diagrams, charts, programs, algorithms, or circuit application examples contained in these materials. All information contained in these materials, including product data, diagrams, charts, programs and algorithms represents information on products at the time of publication of these materials, and are subject to change by Steifpower Technology without notice due to product improvements or other reasons.

It is therefore recommended that customers contact Steifpower Technology or an authorized Steifpower Technology distributor for the latest product information before purchasing a product listed herein.

The information described here may contain technical inaccuracies or typographical errors.

Steifpower Technology assumes no responsibility for any damage, liability, or other loss arising from these inaccuracies or errors.

Please also pay attention to information published by Steifpower Technology by various means including our website home page (<http://www.steifpower.com>).

When using any or all of the information contained in these materials, including product data diagrams, charts, programs, and algorithms, please be sure to evaluate all information as a total system before making a final decision on the applicability of the information and products.

Steifpower Technology assumes no responsibility for any damage, liability or other loss resulting from the information contained herein.

The prior written approval of Steifpower Technology is necessary to reprint or reproduce in whole or in part these materials.

Please contact Steifpower Technology or an authorized distributor for further details on these materials or the products contained herein.