

Bridge Rectifiers

Features

- Universal 3-way terminals: snap-on, wire wrap-around, or PCB mounting
- High surge current capability
- Low thermal resistance
- Solder dip 275 °C max. 7 s, per JESD 22-B106

Typical Applications

General purpose use in AC/DC bridge full wave rectification for power supply, home appliances, office equipment, industrial automation applications.

Mechanical Data

- **Package:** GBPC, GBPC-W
Molding compound meets UL 94 V-0 flammability rating, RoHS-compliant
- **Terminals:** Tin plated leads, solderable per J-STD-002 and JESD22-B102
Suffix letter "W" added to indicate wire leads(e.g. GBPC3510W).

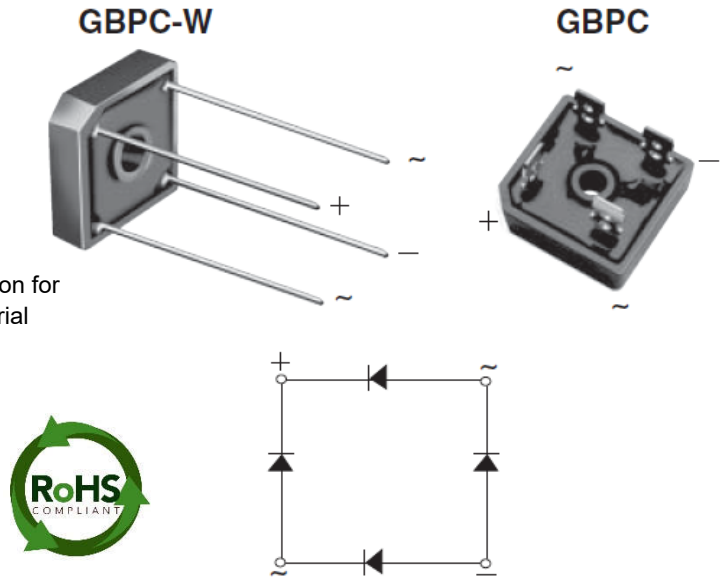

■ Maximum Ratings (T_a=25°C Unless otherwise specified)

PARAMETER	SYMBOL	UNIT	GBPC35 005	GBPC35 01	GBPC35 02	GBPC35 04	GBPC35 06	GBPC35 08	GBPC35 10
Device marking code			GBPC35005	GBPC3501	GBPC3502	GBPC3504	GBPC3506	GBPC3508	GBPC3510
Repetitive Peak Reverse Voltage	VRRM	V	50	100	200	400	600	800	1000
Average Rectified Output Current @60Hz sine wave, R-load, With heatsink, T _c =55°C	I _O	A	35						
Surge(Non-repetitive)Forward Current @60HZ Half- sine Wave, 1 cycle, T _a =25°C	I _{FSM}	A	400						
Current Squared Time @1ms≤t≤8.3ms T _j =25°C, Rating of per diode	I ² t	A ² S	660						
Storage Temperature	T _{stg}	°C	-55 ~+150						
Junction Temperature	T _j	°C	-55 ~+150						
Dielectric Strength, Terminals to case, AC 1 minute	V _{dis}	KV	2.5						
Mounting Torque	TOR	kg·cm	10						

■ Electrical Characteristics (T_a=25°C Unless otherwise specified)

PARAMETER	SYMBOL	UNIT	TEST CONDITIONS	GBPC35 005	GBPC35 01	GBPC35 02	GBPC35 04	GBPC35 06	GBPC35 08	GBPC35 10
Maximum instantaneous forward voltage drop per diode	V _{FM}	V	I _{FM} =17.5A	1.1						
Maximum DC reverse current at rated DC blocking voltage per diode	I _{RRM}	μA	V _{RM} =VRRM	10						

■ Thermal Characteristics (T_a=25°C Unless otherwise specified)

PARAMETER	SYMBOL	UNIT	GBPC35 005	GBPC35 01	GBPC35 02	GBPC35 04	GBPC35 06	GBPC35 08	GBPC35 10
Thermal Resistance Between junction and case, With heatsink	R _{θ J-C}	°C/W	1.35						

Ordering Information (Example)

PREFERRED P/N	PACKAGE CODE	UNIT WEIGHT(g)	MINIMUM PACKAGE(pcs)	INNER BOX QUANTITY(pcs)	OUTER CARTON QUANTITY(pcs)	DELIVERY MODE
GBPC35005~GBPC3510	A1	Approximate 13.8	50	50	500	Paper Box
GBPC35005W~GBPC3510W	A1	Approximate 13	50	50	500	Paper Box

Characteristics (Typical)

FIG1:Io-Tc Curve

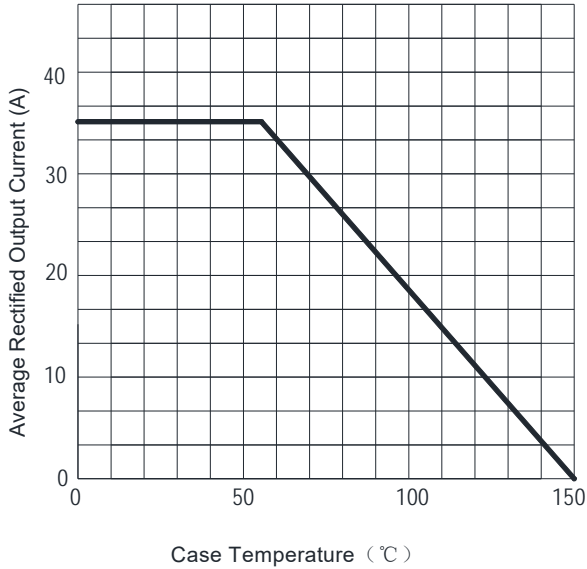

FIG2:Surge Forward Current Capability

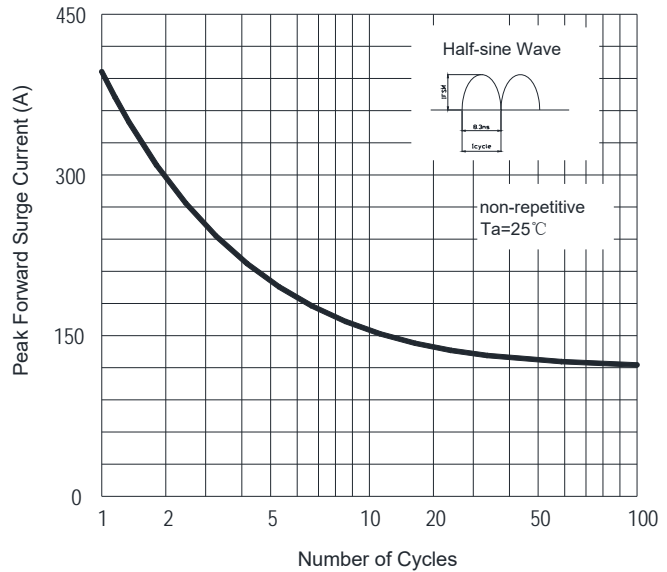

FIG3:Instantaneous Forward Voltage

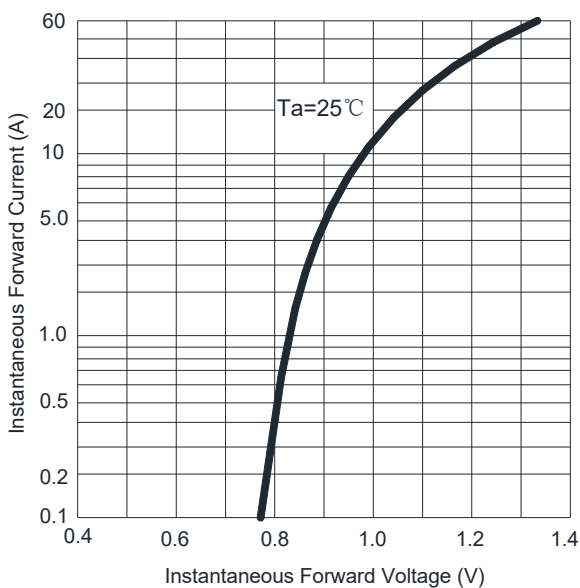
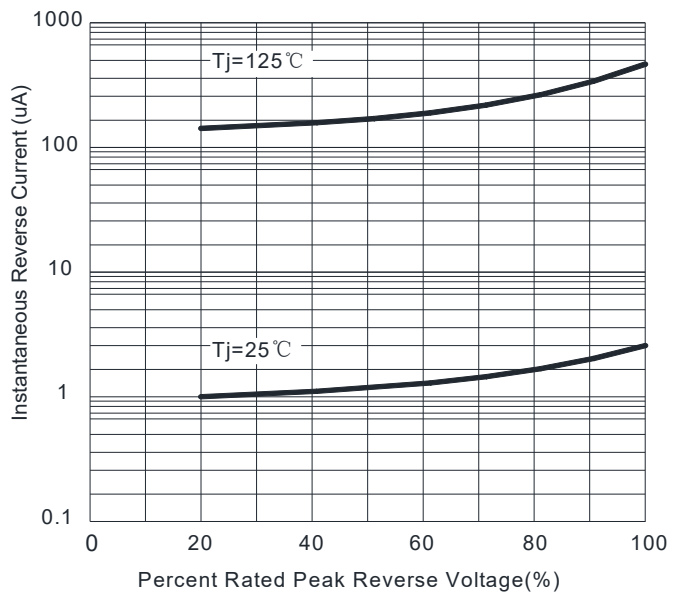
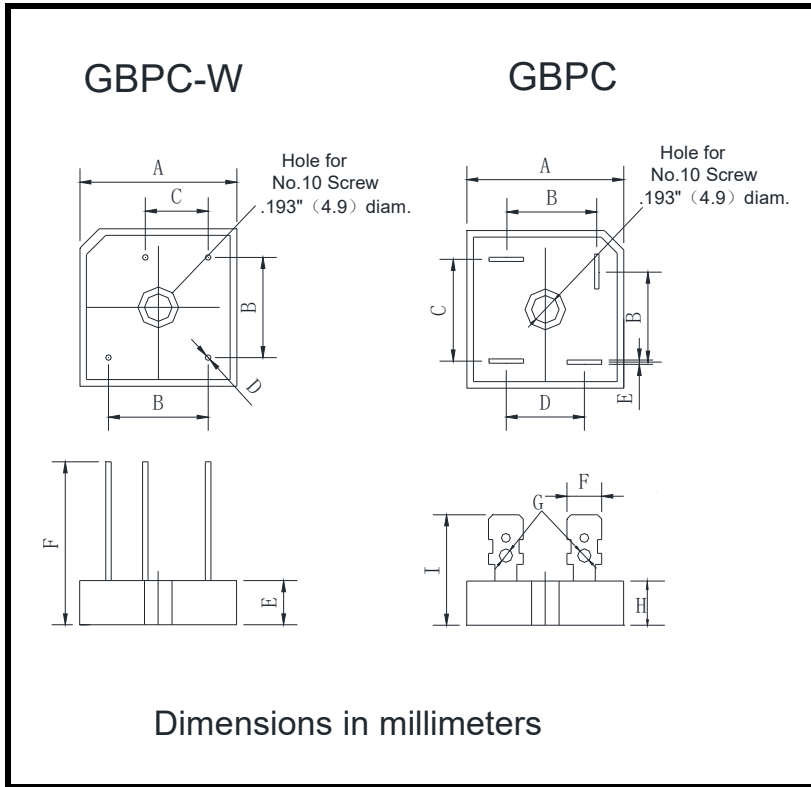

FIG4:Typical Reverse Characteristics



■ Outline Dimensions



GBPC-W		
Dim	Min	Max
A	28.2	28.8
B	17.1	19.1
C	10.4	12.4
D	0.95	1.05
E	7.6	8.2
F	30	

GBPC		
Dim	Min	Max
A	28.2	28.8
B	15.3	17.3
C	17.1	19.1
D	13.2	15.2
E	0.75	0.85
F	6.2	6.4
G	2.2	2.6
H	7.6	8.2
I	19	/

Disclaimers

These materials are intended as a reference to assist our customers in the selection of the Steifpower Technology products best suited to the customer's applications, they do not convey any license under any intellectual property rights, or any other rights, belonging to Steifpower Technology or third party. Steifpower Technology assumes no responsibility for any damage, or infringement of any third-party's rights, originating in the use of any product data, diagrams, charts, programs, algorithms, or circuit application examples contained in these materials. All information contained in these materials, including product data, diagrams, charts, programs and algorithms represents information on products at the time of publication of these materials, and is subject to change by Steifpower Technology without notice due to product improvements or other reasons.

It is therefore recommended that customers contact Steifpower Technology or an authorized Steifpower Technology representative for the latest product information before purchasing a product listed herein.

The information described here may contain technical inaccuracies or typographical errors.

Steifpower Technology assumes no responsibility for any damage, liability, or other loss arising from these inaccuracies or errors.

Please also pay attention to information published by Steifpower Technology by various means including our website home page (<http://www.steifpower.com>).

When using any or all of the information contained in these materials, including product data diagrams, charts, programs, and algorithms, please be sure to evaluate all information as a total system before making a final decision on the applicability of the information and products.

Steifpower Technology assumes no responsibility for any damage, liability or other loss resulting from the information contained herein.

The prior written approval of Steifpower Technology is necessary to reprint or reproduce in whole or in part these materials.

Please contact Steifpower Technology or an authorized distributor for further details on these materials or the products contained herein.