

Bridge Rectifiers

Features

- UL recognition, file #E230084
- Ideal for printed circuit boards
- High surge current capability
- Solder dip 275 °C max. 7 s, per JESD 22-B106

Typical Applications

General purpose use in AC/DC bridge full wave rectification for monitor, TV, printer, power supply, switching mode power supply, adapter, audio equipment, and home appliances applications.

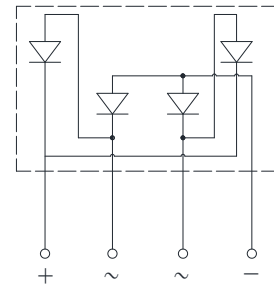
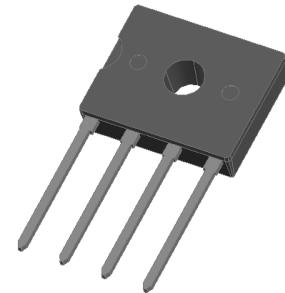

Mechanical Data

- **Package:** D3K
Molding compound meets UL 94 V-0 flammability rating, RoHS-compliant
- **Terminals:** Tin plated leads, solderable per J-STD-002 and JESD22-B102
- **Polarity:** As marked on body

■ Maximum Ratings ($T_a=25^\circ\text{C}$ Unless otherwise specified)

PARAMETER	SYMBOL	UNIT	D3UB05	D3UB10	D3UB20	D3UB40	D3UB60	D3UB80	D3UB100
Device marking code			D3UB05	D3UB10	D3UB20	D3UB40	D3UB60	D3UB80	D3UB100
Repetitive peak reverse voltage	VRRM	V	50	100	200	400	600	800	1000
Average rectified output current @60Hz sine wave, R-load	IO	A	3.0						
			1.2						
Surge(non-repetitive)forward current @60Hz half sine wave, 1 cycle, $T_j=25^\circ\text{C}$	IFSM	A	90						
Current squared time @ $1\text{ms} \leq t \leq 8.3\text{ms}$ $T_j=25^\circ\text{C}$, Rating of per diode	I^2t	A^2s	33						
Storage temperature	T_{stg}	$^\circ\text{C}$	-55 ~+150						
Junction temperature	T_j	$^\circ\text{C}$	-55 ~+150						
Dielectric strength @ Terminals to case, AC 1 minute	Vdis	KV	2						
Mounting torque @Recommend torque: 5kg • cm	Tor	kg • cm	8						

■ Electrical Characteristics ($T_a=25^\circ\text{C}$ Unless otherwise specified)

PARAMETER	SYMBOL	UNIT	TEST CONDITIONS	D3UB05	D3UB10	D3UB20	D3UB40	D3UB60	D3UB80	D3UB100
Maximum instantaneous forward voltage drop per diode	V_F	V	IFM=1.5A	1.00						
Maximum DC reverse current at rated DC blocking voltage per diode	IRRM	μA	VRM=VRRM	5						

■ **Thermal Characteristics** ($T_a=25^\circ\text{C}$ Unless otherwise specified)

PARAMETER		SYMBOL	UNIT	D3UB05	D3UB10	D3UB20	D3UB40	D3UB60	D3UB80	D3UB100
Thermal resistance	Between junction and ambient, Without heatsink	R θ J-A	$^\circ\text{C}/\text{W}$	55.0						
	Between junction and case, With heatsink	R θ J-C		1.5						

■ **Ordering Information (Example)**

PREFERRED P/N	PACKING CODE	UNIT WEIGHT(g)	MINIMUM PACKAGE(pcs)	INNER BOX QUANTITY(pcs)	OUTER CARTON QUANTITY(pcs)	DELIVERY MODE
D3UB05-D3UB100	B1	Approximate 1.358	25	1500	6000	TUBE

■ **Characteristics (Typical)**

FIG1:Io-Tc Curve

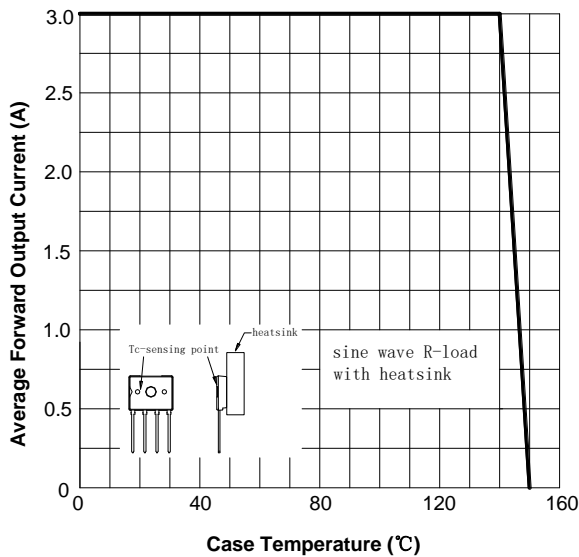

FIG2:Surge Forward Current Capability

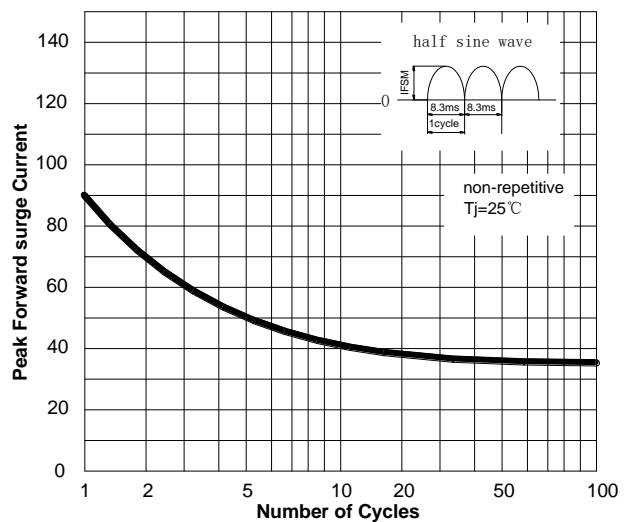

FIG3: Forward Voltage

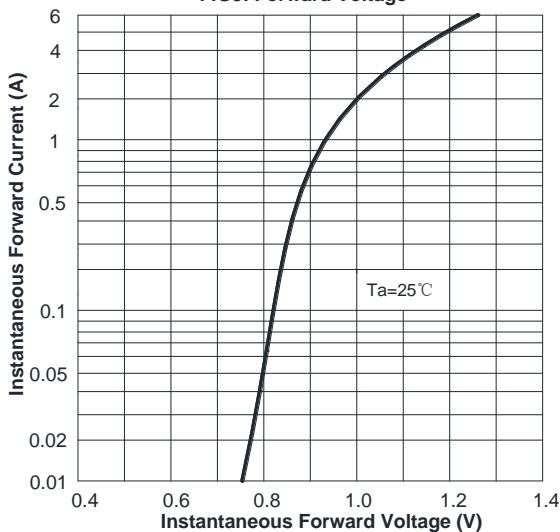
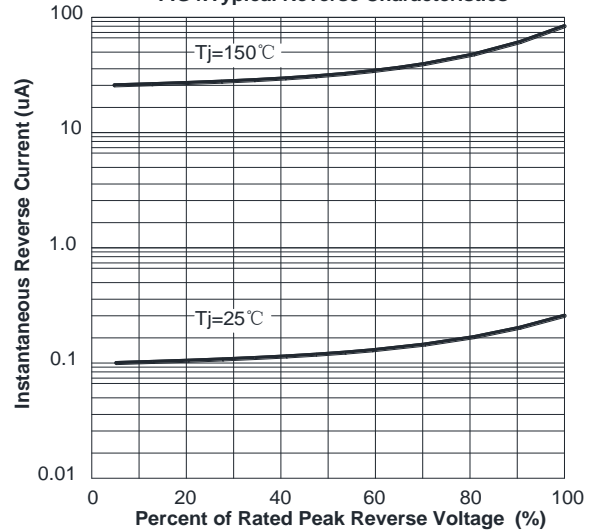
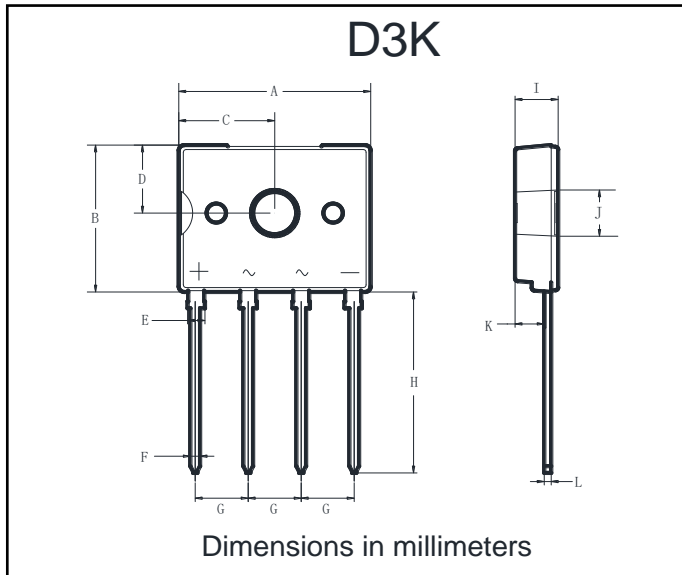

FIG4:Typical Reverse Characteristics



■ **Outline Dimensions**



D3K		
Dim	Min	Max
A	13.30	14.30
B	10.30	11.30
C	6.40	7.40
D	4.50	5.50
E	1.05	1.45
F	0.60	0.85
G	3.70	3.90
H	13.10	13.50
I	2.60	3.60
J	3.10	3.40
K	2.00	2.20
L	0.40	0.60

Disclaimers

These materials are intended as a reference to assist our customers in the selection of the Steifpower Technology products best suited to the customer's applications, they do not convey any license under any intellectual property rights, or any other rights, belonging to Steifpower Technology or third party. Steifpower Technology assumes no responsibility for any damage, or infringement of any third-party's rights, originating in the use of any product data, diagrams, charts, programs, algorithms, or circuit application examples contained in these materials. All information contained in these materials, including product data, diagrams, charts, programs and algorithms represents information on products at the time of publication of these materials, and is subject to change by Steifpower Technology without notice due to product improvements or other reasons.

It is therefore recommended that customers contact Steifpower Technology or an authorized Steifpower Technology representative for the latest product information before purchasing a product listed herein.

The information described here may contain technical inaccuracies or typographical errors.

Steifpower Technology assumes no responsibility for any damage, liability, or other loss arising from these inaccuracies or errors.

Please also pay attention to information published by Steifpower Technology by various means including our website home page (<http://www.steifpower.com>).

When using any or all of the information contained in these materials, including product data diagrams, charts, programs, and algorithms, please be sure to evaluate all information as a total system before making a final decision on the applicability of the information and products.

Steifpower Technology assumes no responsibility for any damage, liability or other loss resulting from the information contained herein.

The prior written approval of Steifpower Technology is necessary to reprint or reproduce in whole or in part these materials.

Please contact Steifpower Technology or an authorized distributor for further details on these materials or the products contained herein.