

## Bridge Rectifiers

### Features

- UL recognition, file #E230084 Universal 3-way terminals: snap-on, wire wrap-around, or PCB mounting
- High surge current capability
- Low thermal resistance
- Solder dip 275 °C max. 7 s, per JESD 22-B106

### Typical Applications

General purpose use in AC/DC bridge full wave rectification for power supply, home appliances, office equipment, industrial automation applications.

### Mechanical Data

- Package:** BR, BR-W

Molding compound meets UL 94 V-0 flammability rating, RoHS-compliant

- Terminals:** Tin plated leads, solderable per J-STD-002 and JESD22-B102

Suffix letter "W" added to indicate wire leads(e.g. BR2510W)

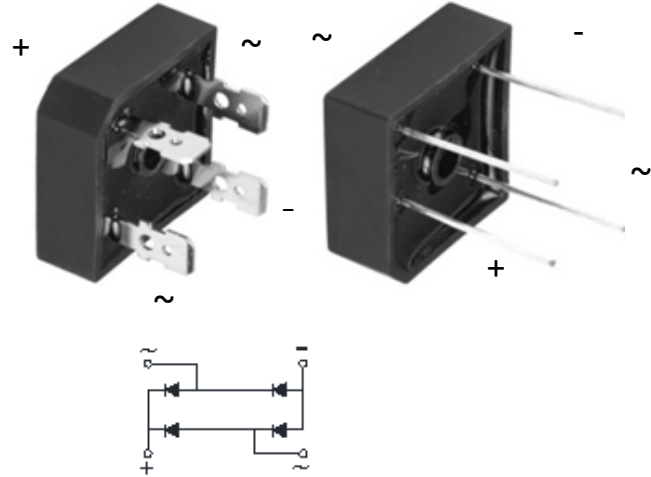

### ■ Maximum Ratings ( $T_a=25^\circ\text{C}$ Unless otherwise specified)

PARAMETER	SYMBOL	UNIT	BR25005	BR2501	BR2502	BR2504	BR2506	BR2508	BR2510
Device marking code			BR25005	BR2501	BR2502	BR2504	BR2506	BR2508	BR2510
Repetitive Peak Reverse Voltage	VRRM	V	50	100	200	400	600	800	1000
Average Rectified Output Current @60Hz sine wave, R-load, With heatsink, $T_c=55^\circ\text{C}$	$I_O$	A	25						
Surge(Non-repetitive)Forward Current @60HZ Half- sine Wave, 1 cycle, $T_a=25^\circ\text{C}$	IFSM	A	400						
Current Squared Time @1ms≤t≤8.3ms $T_j=25^\circ\text{C}$ , Rating of per diode	$I^2t$	A <sup>2</sup> S	660						
Storage Temperature	Tstg	°C	-55 ~+150						
Junction Temperature	$T_j$	°C	-55 ~+150						
Dielectric Strength, Terminals to case, AC 1 minute	$V_{dis}$	KV	2.5						
Mounting Torque	TOR	kg·cm	10						

### ■ Electrical Characteristics ( $T_a=25^\circ\text{C}$ Unless otherwise specified)

PARAMETER	SYMBOL	UNIT	TEST CONDITIONS	BR25005	BR2501	BR2502	BR2504	BR2506	BR2508	BR2510
Maximum instantaneous forward voltage drop per diode	V <sub>FM</sub>	V	IFM=12.5A	1.1						
Maximum DC reverse current at rated DC blocking voltage per diode	I <sub>RRM</sub>	μA	V <sub>RM</sub> =V <sub>RRM</sub>	10						

■ **Thermal Characteristics** ( $T_a=25^\circ\text{C}$  Unless otherwise specified)

PARAMETER		SYMBOL	UNIT	BR25005	BR2501	BR2502	BR2504	BR2506	BR2508	BR2510	
Thermal Resistance	Between junction and case, With heatsink	$R_{\theta J-C}$	$^\circ\text{C/W}$	2.1							

■ **Ordering Information** (Example)

PREFERRED P/N	PACKAGE CODE	UNIT WEIGHT(g)	MINIMUM PACKAGE(pcs)	INNER BOX QUANTITY(pcs)	OUTER CARTON QUANTITY(pcs)	DELIVERY MODE
BR25005~BR2510	A1	Approximate 18.6	50	50	500	Paper Box
BR25005W~BR2510W	A1	Approximate 16.5	50	50	500	Paper Box

■ **Characteristics** (Typical)

FIG1:Io-Tc Curve

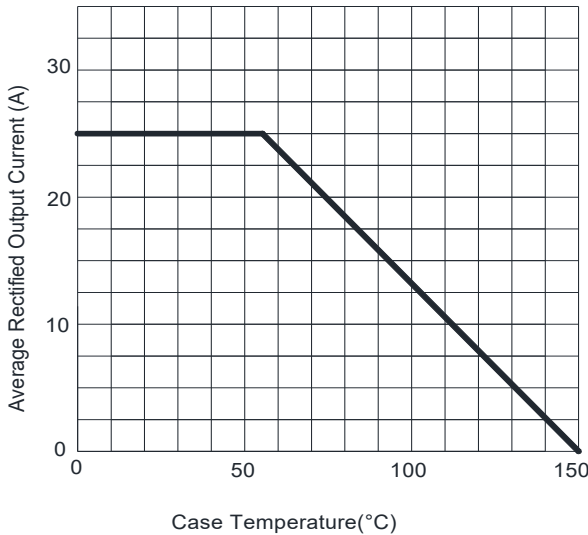

FIG2:Surge Forward Current Capability

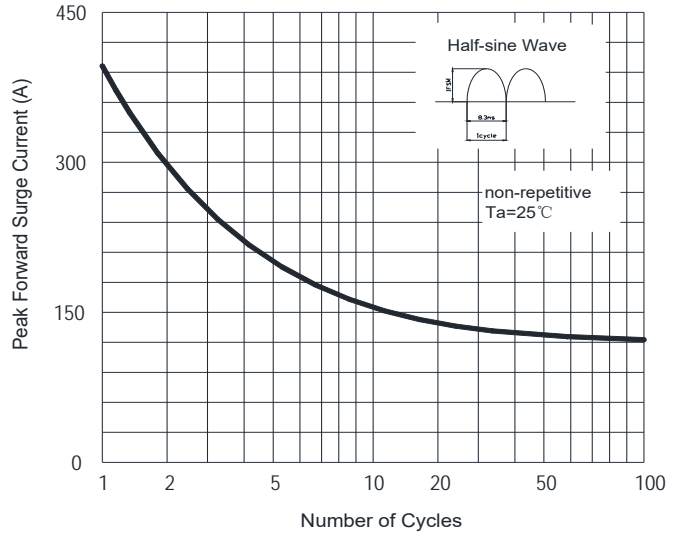

FIG3:Instantaneous Forward Voltage

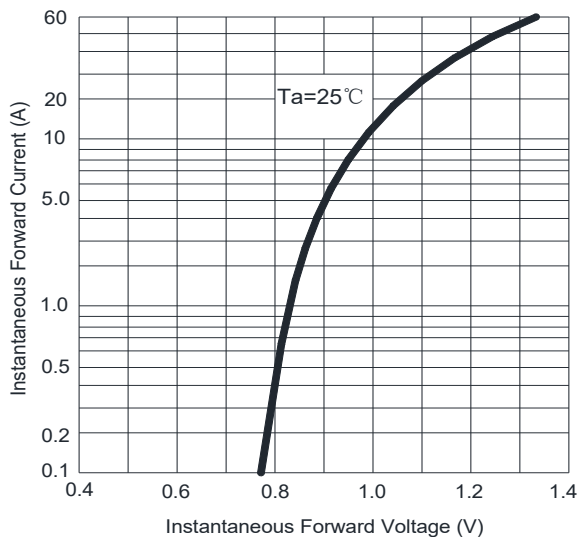
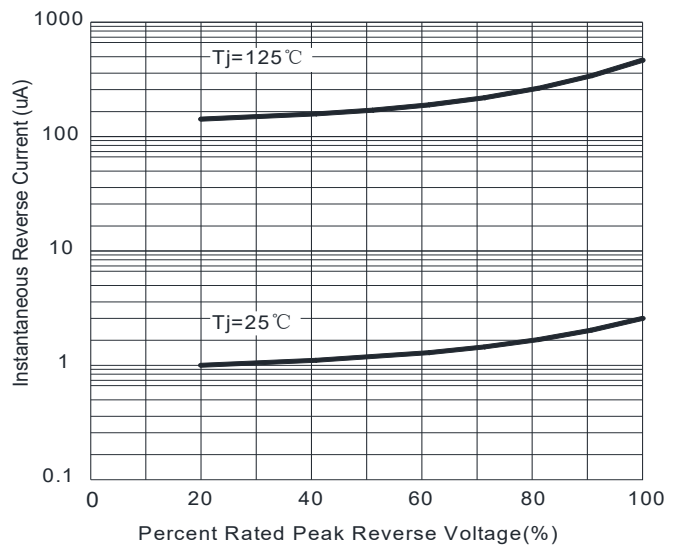
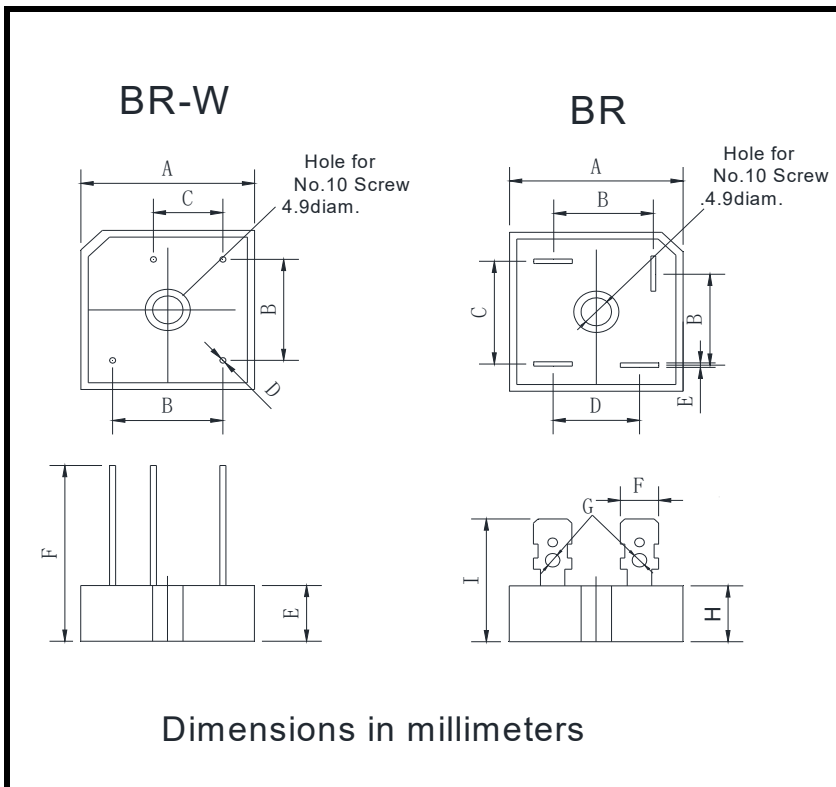

FIG4:Typical Reverse Characteristics



■ **Outline Dimensions**



Dimensions in millimeters

BR-W		
Dim	Min	Max
A	28.2	28.8
B	17.1	19.1
C	10.4	12.4
D	0.95	1.05
E	10.8	11.2
F	30	/

BR		
Dim	Min	Max
A	28.2	28.8
B	15.3	17.3
C	17.1	19.1
D	13.2	15.2
E	0.75	0.85
F	6.2	6.4
G	2.3	2.5
H	10.8	11.2
I	19	/

**Disclaimers**

These materials are intended as a reference to assist our customers in the selection of the Steifpower Technology products best suited to the customer's applications, they do not convey any license under any intellectual property rights, or any other rights, belonging to Steifpower Technology or third party. Steifpower Technology assumes no responsibility for any damage, or infringement of any third-party's rights, originating in the use of any product data, diagrams, charts, programs, algorithms, or circuit application examples contained in these materials. All information contained in these materials, including product data, diagrams, charts, programs and algorithms represents information on products at the time of publication of these materials, and are subject to change by Steifpower Technology without notice due to product improvements or other reasons.

It is therefore recommended that customers contact Steifpower Technology or an authorized Steifpower Technology distributor for the latest product information before purchasing a product listed herein.

The information described here may contain technical inaccuracies or typographical errors.

Steifpower Technology assumes no responsibility for any damage, liability, or other loss arising from these inaccuracies or errors.

Please also pay attention to information published by Steifpower Technology by various means including our website home page (<http://www.steifpower.com>).

When using any or all of the information contained in these materials, including product data diagrams, charts, programs, and algorithms, please be sure to evaluate all information as a total system before making a final decision on the applicability of the information and products.

Steifpower Technology assumes no responsibility for any damage, liability or other loss resulting from the information contained herein.

The prior written approval of Steifpower Technology is necessary to reprint or reproduce in whole or in part these materials.

Please contact Steifpower Technology or an authorized distributor for further details on these materials or the products contained herein.